

# AXS Handheld OTDR



---

Copyright © 2024–2026 EXFO Inc. All rights reserved. No part of this publication may be reproduced, stored in a retrieval system or transmitted in any form, be it electronically, mechanically, or by any other means such as photocopying, recording or otherwise, without the prior written permission of EXFO Inc. (EXFO).

Information provided by EXFO is believed to be accurate and reliable. However, no responsibility is assumed by EXFO for its use nor for any infringements of patents or other rights of third parties that may result from its use. No license is granted by implication or otherwise under any patent rights of EXFO.

EXFO's Commerce And Government Entities (CAGE) code under the North Atlantic Treaty Organization (NATO) is 0L8C3.

The information contained in this publication is subject to change without notice.

### ***Trademarks***

EXFO's trademarks have been identified as such. However, the presence or absence of such identification does not affect the legal status of any trademark.

Where applicable, the Bluetooth<sup>®</sup> word mark and logos are registered trademarks owned by Bluetooth SIG, Inc. and any use of such marks by EXFO Inc. is under license. Where applicable, the MTP<sup>®</sup> mark is a registered trademark of US Conec Ltd. Other third party trademarks and trade names are those of their respective owners.

### ***Units of Measurement***

Units of measurement in this publication conform to SI standards and practices.

### ***Patents***

The exhaustive list of patents is available at [EXFO.com/patent](http://EXFO.com/patent).

Version number: 4.0.0.1

# Contents

Regulatory Information .....	vii
<b>1 Introducing the AXS Handheld OTDR .....</b>	<b>1</b>
Main Features .....	1
Available Options .....	4
LED Indicator Description .....	5
Battery Status Icon Description .....	6
Power Sources .....	7
Temperature Management .....	8
Using Your Handheld OTDR Alone or With the EXFO Exchange mobile application .....	9
Technical Specifications .....	9
Conventions .....	10
<b>2 Safety Information .....</b>	<b>11</b>
General Safety Information .....	11
Other Safety Symbols on Your Unit .....	13
Laser Safety Information .....	14
Laser Safety Information (Units with VFL) .....	15
Electrical Safety Information .....	16
<b>3 Getting Started With Your AXS Handheld OTDR .....</b>	<b>19</b>
Turning on Your Unit .....	19
Turning off Your Unit .....	20
Configuring Your Unit at First Startup .....	21
Understanding the Main Window .....	28
Cleaning and Connecting Optical Fibers .....	31

---

<b>4</b>	<b>Setting up Your Unit .....</b>	<b>33</b>
	Adjusting Brightness .....	33
	Enabling or Disabling Sound Notifications .....	36
	Selecting the Language of Operation .....	37
	Selecting the On-Screen Keyboard .....	43
	Adjusting the Date, Time and Time Zone .....	45
	Selecting the Distance Units .....	47
	Configuring the Sleep Mode .....	49
	Selecting Test Wavelengths .....	52
	Setting Power Checker Thresholds .....	54
	Enabling or Disabling Auto Save .....	56
	Enabling or Disabling Auto Navigation .....	57
	Selecting an Acquisition Mode (AXS-130-SM7/SM8 Models Only) .....	58
	Working With Launch and Receive Test Fibers .....	60
	Working With Pass/Fail Thresholds .....	63
	Configuring the IOR Value .....	68
	Configuring the Shortcut Menu .....	70
	Setting the Detection Thresholds .....	72
	Setting the Acquisition Parameters .....	75
	Setting up Splitter Detection .....	78
	Resetting Your Unit Settings and Data .....	81
	Using the VFL .....	83
<b>5</b>	<b>Testing Fibers .....</b>	<b>86</b>
	Performing Measurements .....	86
	Performing a Measurement Again .....	89
	Monitoring Fibers in Real-Time Mode .....	90
	Measuring Power .....	94
<b>6</b>	<b>Working With Jobs .....</b>	<b>98</b>
	Understanding the My Jobs Page .....	99
	Understanding the Test Points Page .....	100
	Generating Valid Test Point Identifiers .....	101
	Creating Jobs .....	106
	Deleting Jobs .....	111
	Adding Test Points to a Job .....	113
	Deleting Test Points From a Job .....	116
	Working With Test Configurations .....	118
<b>7</b>	<b>Using the Light Source .....</b>	<b>120</b>

---

<b>8</b>	<b>Managing Test Results</b>	<b>127</b>
	Viewing Measurements	127
	Working With Link Summary	130
	Working With the Optical Link Map	131
	Working With the Result Table	134
	Changing an Element Type	136
	Viewing Diagnoses on Elements	137
	Working with the OTDR Trace Viewer	138
	Saving Measurements	140
	Exporting Measurements	141
<b>9</b>	<b>Working With the EXFO Exchange mobile application</b>	<b>144</b>
	Installing the Exchange Mobile Application on Your Smart Device	145
	Enabling or Disabling a Connection With a Smart Device Via the Bluetooth Technology	146
	Enabling or Disabling the Wi-Fi Communication	149
	Synchronizing Job Results With the Smart Device and the Cloud Server	156
<b>10</b>	<b>Maintenance</b>	<b>158</b>
	Cleaning Optical Connectors Using a Mechanical Cleaner	159
	Cleaning the Touchscreen	160
	Recharging the Battery	160
	Battery Maintenance Recommendations	163
	Replacing the Battery	165
	Verifying the Optical Output of Your Unit	171
	Replacing the Click-Out Optical Connector	175
	Updating the Application	178
	Recalibrating the Unit	181
	Recycling and Disposal	182
<b>11</b>	<b>Troubleshooting</b>	<b>183</b>
	Solving Common Problems	183
	Performing Additional Verifications on Your Unit's Connectors	188
	Using the Recovery Mode on Your Unit	194
	Accessing the Online Documentation From the AXS Handheld OTDR	198
	Contacting the Technical Support Group	199
	Viewing System Information	200
	Transportation	201

**12 Warranty .....202**

- General Information .....202
- Gray Market and Gray Market Products .....203
- Liability .....204
- Exclusions .....204
- Certification .....204
- Service and Repairs .....205
- EXFO Service Centers Worldwide .....206

**Index .....207**

## Regulatory Information

### USA Electromagnetic Interference Regulatory Statement

Electronic test and measurement equipment is exempt from FCC part 15, subpart B compliance in the United States of America. However, EXFO Inc. makes reasonable efforts to ensure compliance to the applicable standards.

The limits set by these standards are designed to provide reasonable protection against harmful interference when the equipment is operated in a commercial environment. This equipment generates, uses, and can radiate radio frequency energy and, if not installed and used in accordance with the user documentation, may cause harmful interference to radio communications. Operation of this equipment in a residential area is likely to cause harmful interference in which case the user will be required to correct the interference at his own expense.

## Canada Electromagnetic Interference Regulatory Statement

This equipment generates, uses, and can radiate radio frequency energy and, if not installed and used in accordance with the instruction manual, may cause harmful interference to radio communications. Operation of this equipment in a residential area is likely to cause harmful interference.

Cet équipement génère, utilise et peut émettre de l'énergie radio-fréquence et, s'il n'est pas installé et utilisé conformément à la documentation de l'utilisateur, il peut occasionner une interférence néfaste aux communications radio. L'utilisation de cet équipement dans une zone résidentielle est susceptible d'occasionner une interférence néfaste.

**Caution:** This equipment is not intended for use in residential environments and may not provide adequate protection to radio reception in such environments.

**Attention :** Cet appareil n'est pas destiné à être utilisé dans des environnements résidentiels et peut ne pas assurer la protection adéquate à la réception radioélectrique dans ce type d'environnements.

This is a class A, group 1 product.

Ceci est un produit de classe A, groupe 1.

- ▶ Class A equipment: Equipment that is, by virtue of its characteristics, highly unlikely to be used in a residential environment, including a home business shall be classified as class A and shall comply with the class A limits specified in the applicable ICES standard. Characteristics considered in this assessment include price, marketing and advertising methodology, the degree to which the functional design inhibits applications suitable to residential environments, or any combination of features that would effectively preclude the use of such equipment in a residential environment.

Classe A : Matériel qui, en raison de ses caractéristiques, ne sera fort probablement pas utilisé dans un milieu domiciliaire ni par des entreprises établies à domicile. Parmi les caractéristiques considérées dans cette évaluation, il y a le prix, les méthodes de commercialisation et de publicité, la mesure dans laquelle les fonctions de l'appareil font qu'il ne se prête pas à des applications convenant au milieu domiciliaire ou toute combinaison de ces caractéristiques qui aurait pour conséquence d'en prévenir effectivement l'utilisation à domicile. Utilisé également pour indiquer les limites d'émission correspondantes qui s'appliquent à un tel matériel.

- ▶ Class B equipment: Equipment that cannot be classified as Class A shall comply with the Class B limits specified in the applicable ICES standard.

Classe B : Matériel qui ne peut pas être inclus dans la classe A. Utilisé également pour indiquer les limites d'émission correspondantes qui s'appliquent à un tel matériel.

- **Group 1 equipment:** group 1 contains all equipment which is not classified as group 2 equipment, and includes equipment such as laboratory and scientific equipment, industrial process, measurement and control equipment.

**Group 2 equipment:** group 2 contains all ISM RF equipment in which radio-frequency energy in the frequency range 9 kHz to 400 GHz is intentionally generated and used or only used locally, in the form of electromagnetic radiation, inductive and/or capacitive coupling, for the treatment of material for inspection/analysis purposes, or for transfer of electromagnetic energy.

Appareils du groupe 1 : le groupe 1 réunit tous les appareils compris dans le domaine d'application de la présente Norme, qui ne sont pas classés comme étant des appareils du groupe 2. Le groupe 1 inclut les appareils scientifiques et de laboratoire, les processus industriels, appareils de mesure ou de contrôle.

Appareils du groupe 2 : le groupe 2 réunit tous les appareils ISM à fréquences radioélectriques dans lesquels de l'énergie à fréquences radioélectriques dans la plage de fréquences comprises entre 9 kHz et 400 GHz est produite et utilisée volontairement ou uniquement utilisée localement sous forme de rayonnement électromagnétique, de couplage inductif et/ou capacitif, pour le traitement de la matière, à des fins d'examen ou d'analyse ou pour le transfert d'énergie électromagnétique.

## Supplier's Declaration of Conformity (SDoC)

The SDoC for your product is as follows:

CAN ICES-001 (A) / NMB-001 (A)

## Electromagnetic Compatibility Regulatory Statement

Warning: This is a class A product. In a domestic environment, this product may cause radio interference in which case the user may be required to take adequate measures. Your product is suitable for use in basic electromagnetic environments.

## General Wireless Compliance Related Information

Your unit comes with an internal wireless module (adapter) and antenna for which the information hereafter applies:

This product does not contain any wireless user-serviceable components. Any unauthorized product changes or modifications will invalidate warranty and all applicable regulatory certifications and approvals.

## Canada and USA Wireless Compliance Related Information

Your unit comes with an internal wireless module (adapter) and antenna for which the information hereafter applies:

This product does not contain any wireless user-serviceable components. Any unauthorized product changes or modifications will invalidate warranty and all applicable regulatory certifications and approvals.

- This device complies with Part 15 of the FCC Rules.
- This device contains license-exempt transmitter(s)/receiver(s) that comply with Innovation, Science and Economic Development Canada's license-exempt RSS standards.

L'émetteur/récepteur exempt de licence contenu dans le présent appareil est conforme aux CNR d'Innovation, Sciences et Développement économique Canada applicables aux appareils radio exempts de licence.

- Operation is subject to the following two conditions:
  - (1) This device may not cause harmful interferenceand
  - (2) this device must accept any interference received, including interference that may cause undesired operation of the device.

L'exploitation est autorisée aux deux conditions suivantes :

- (1) L'appareil ne doit pas produire de brouillage;
- (2) L'appareil doit accepter tout brouillage radioélectrique subi, même si le brouillage est susceptible d'en compromettre le fonctionnement.

### ***Use in Specific Environments:***

- The use of wireless products in hazardous locations is limited by the constraints posed by the safety directors of such environments.
- The use of wireless products in hospitals is restricted to the limits set forth by each hospital.

### ***Radiation Exposure Statement:***

- The product complies with the US/Canada portable RF exposure limit set forth for an uncontrolled environment (general public use) and is safe for intended operation as described in this user documentation.
- Further RF exposure reduction can be achieved if the device can be kept as far as possible from the user's body.

## **EU and UK Wireless Compliance Related Information**

The information about the Bluetooth and Wi-Fi frequency bands is as follows:

- Bluetooth: Between the frequencies 2400.0 MHz - 2483.5 MHz.  
The output power is 4 dBm typical.
- Wi-Fi: Between the frequencies 2400.0 MHz - 2483.5 MHz.  
The maximum output power is 18.5 dBm typical.

This is a 2.4 GHz wideband transmission system (transceiver), intended for use in all EU member states, United Kingdom, and EFTA countries, except in France and Italy where restrictive use applies.

In Italy, the end-user should apply for a license at the national spectrum authorities in order to obtain authorization to use the device for setting up outdoor radio links and/or for supplying access to telecommunications and/or network services.

This device may not be used for setting up radio links in France, and in some areas the RF output power may be limited to 10 mW EIRP in the frequency range of 2454 - 2483.5 MHz. For detailed information, the end-user should contact the national spectrum authority in France.

### **Local Restrictions on 802.11a, 802.11b, 802.11d, 802.11g, 802.11n, and 802.11ac Radio Usage**

Due to the fact that the frequencies used by 802.11a, 802.11b, 802.11d, 802.11g, 802.11n, and 802.11ac wireless LAN devices may not yet be harmonized in all countries, 802.11a, 802.11b, 802.11d, 802.11g, 802.11n, and 802.11ac products are designed for use only in specific countries, and are not allowed to be operated in countries other than those of designated use. As a user of these products, you are responsible for ensuring that the products are used only in the countries for which they were intended and for verifying that they are configured with the correct selection of frequency and channel for the country of use.

## Simplified EU and UK Declaration of Conformity

The full text of the declaration of conformity is available at the following Internet address: [www.exfo.com/en/resources/legal-documentation](http://www.exfo.com/en/resources/legal-documentation).

## EU Economic Operator

**EXFO Solutions SAS**

2, rue Jacqueline Auriol,

Saint-Jacques-de-la-Lande,

35091 Rennes Cedex 9

FRANCE

# 1

## Introducing the AXS Handheld OTDR

The AXS Handheld OTDR is an ultra-portable and fit-for-purpose OTDR that allows to characterize an optical link end to end, including its elements such as splices or connectors. The tests are grouped in easy to set up jobs that you can create and store locally or through the EXFO Exchange mobile application.

The AXS Handheld OTDR includes a broadband power meter, which can detect different tones from a source (270 Hz, 330 Hz, 1 kHz and 2 kHz), plus a visual fault locator that emits light, either in continuous or blinking mode, to trace fibers and identify breaks and macrobends.

### Main Features

Your AXS Handheld OTDR includes the following features:

- Color display
- Capacitive touchscreen
- Rechargeable battery
- Operates with USB power, even when charging battery
- Bluetooth® connectivity with mobile device
- Easy software updates using an USB or Wi-Fi connection
- Cloud connectivity and reporting available with the EXFO Exchange mobile app
- Inline source
- Inline power meter
- Output diagnoses
- Click-out connector with interchangeable adapter
- VFL
- Test modes (Optimodes) available on AXS-130 models

**Front panel**

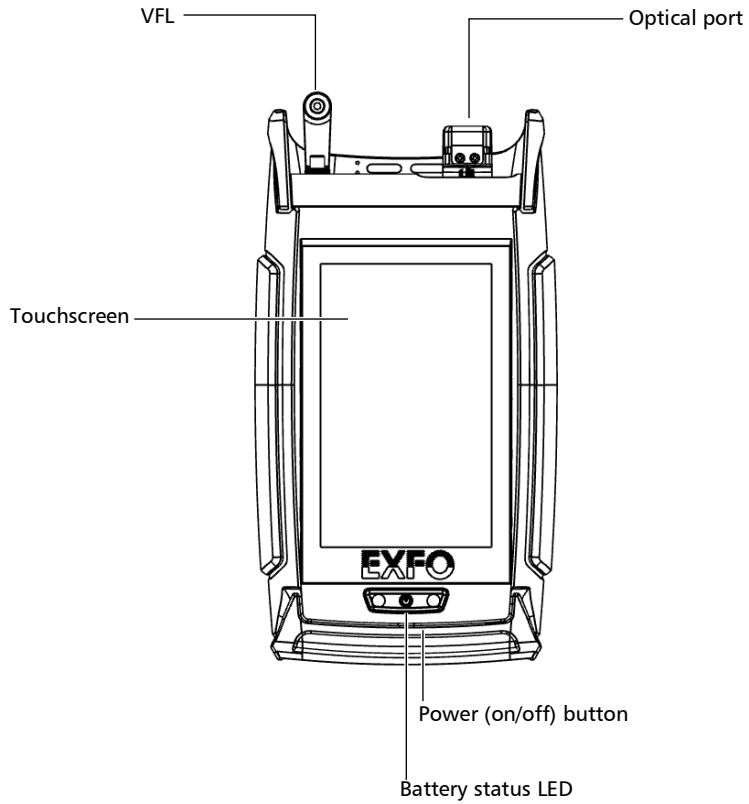

### Top panel

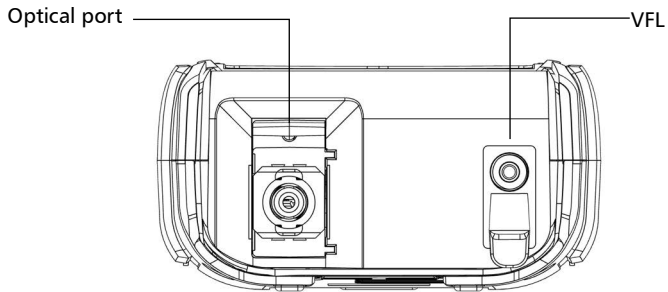

### Bottom panel

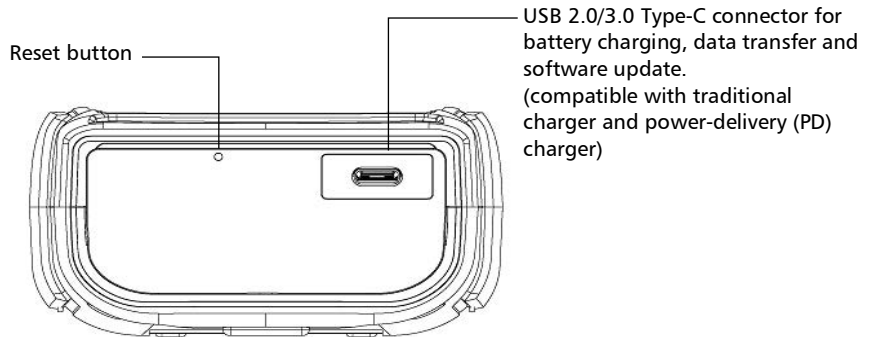

## Available Options

Several options are available for the Handheld OTDR:

Option	Description
AXS-120-NRF	<ul style="list-style-type: none"> <li>➤ 1310/1550 nm, 34/32 dB (9/125 <math>\mu\text{m}</math>)</li> <li>➤ Swap-out connector with interchangeable adapter</li> <li>➤ Inline Light Source and Power Checker</li> <li>➤ Integrated VFL</li> </ul>
AXS-120	<ul style="list-style-type: none"> <li>➤ 1310/1550 nm, 34/32 dB (9/125 <math>\mu\text{m}</math>)</li> <li>➤ Wi-Fi/Bluetooth</li> <li>➤ Swap-out connector with interchangeable adapter</li> <li>➤ Inline Light Source and Power Checker</li> <li>➤ Integrated VFL</li> </ul>
AXS-130- NRF	<ul style="list-style-type: none"> <li>➤ 1650 nm, 39 dB (9/125 <math>\mu\text{m}</math>)</li> <li>➤ Swap-out connector with interchangeable adapter</li> <li>➤ Inline Light Source and Power Checker</li> <li>➤ Integrated VFL</li> <li>➤ Predefined test modes (Optimodes) available</li> </ul>
AXS-130	<ul style="list-style-type: none"> <li>➤ 1310/1550 nm, 39/39 dB (9/125 <math>\mu\text{m}</math>) (SM1)</li> <li>➤ 1310/1550/1650 nm (Live), 39/39/39 dB (9/125 <math>\mu\text{m}</math>) (SM8)</li> <li>➤ 1650 nm, 39 dB (9/125 <math>\mu\text{m}</math>) (SM7)</li> <li>➤ Wi-Fi/Bluetooth</li> <li>➤ Swap-out connector with interchangeable adapter</li> <li>➤ Inline Light Source and Power Checker</li> <li>➤ Integrated VFL</li> <li>➤ Predefined test modes (Optimodes) available</li> </ul>



## LED Indicator Description

The LED indicator, located on the power button, provides you with information about the battery status.

Unit	Status	Meaning
Connected to an external power source	Off	The external power source does not provide sufficient power to charge the battery.
	Blue	The battery is fully charged.
	Blue, blinking – slow blinking	The battery is charging.
	Blue, blinking – fast blinking	The battery charge has been interrupted, possibly because the unit may not be within the recommended charging temperatures. For more information, see <i>Equipment Ratings</i> on page 17.
	Red, fast blinking	Charge or temperature error.
	Red, steady for 5 seconds	The battery level is too low to start the unit.
	White	The unit is starting up.
	Magenta	Battery is disconnected.
	Not connected to an external power source	Off
Red, steady.		The battery level is less than 10 %.
Red, steady for 5 seconds		The unit is off and the battery level is too low to start the unit.
White		The unit is starting up.

## Battery Status Icon Description

The battery status icon is shown in the upper right corner of the title bar. It complements the information provided by the unit's LED.

Icon	Meaning
	The portion of the icon that appears in white in the title bar (in black here) reflects the current battery level.
	A red icon indicates that the battery level is running low and that you should connect the unit to a power outlet.
	A flash symbol indicates that the unit is charging.

## Power Sources

The Handheld OTDR operates with the following power sources:

- Indoor use only: USB power adapter connected to a power outlet (fastest way to charge the battery).

**Note:** *The standard USB ports of a computer cannot power your unit or charge its battery while the unit is on. If you connect your unit to such a USB port with the USB cable, the unit will still consume battery power. If the unit is off when you connect it to the USB port of a computer, its battery could charge, but slowly.*

**Note:** *If you have a vehicle equipped with dedicated USB charging ports, you could connect your unit to one of these ports to charge the battery. The actual results will vary with each vehicle. You could also use a certified USB power bank (portable charger) to charge your unit.*

- Indoor and outdoor use: One lithium-polymer (Li-Po) rechargeable battery (automatically takes over if you disconnect the unit from its external power source). You can switch from an external power source to battery power or vice versa without affecting operation.

**Note:** *You can replace the battery yourself (see Replacing the Battery on page 165), but not the clock battery.*

**Note:** *When the ambient temperature is below 0 °C (32 °F) or when it reaches or exceeds about 40 °C (104 °F), the battery can either charge more slowly than usual, or not charge at all, depending on the internal temperature of your unit.*

For more information, see *Electrical Safety Information* on page 16.

## Temperature Management

The internal temperature of your unit will vary with the ambient temperature, but also with the type of tests you perform and their intensity.

Your unit has also been designed to adapt its behavior as necessary to regulate its temperature. For this reason, in high-temperature conditions, you could receive warning messages. If the temperature keeps rising and reaches the limit your unit will turn off as self-protection.

For more information on the effects of temperature on battery charging, see *Power Sources* on page 7.



### IMPORTANT

For optimum performance of your unit:

- Ensure that it remains within the recommended operation and storage temperatures (see *Equipment Ratings* on page 17).
- Avoid leaving your unit in an overheated vehicle. You may have to let your unit cool down before being able to use it.
- Ensure that your unit is normally protected from direct sunlight (during use and storage).

## **Using Your Handheld OTDR Alone or With the EXFO Exchange mobile application**

You can use the AXS Handheld OTDR as a standalone unit or in association with a smart device equipped with the EXFO Exchange mobile application.

- Using your Handheld OTDR as a standalone unit enables you to perform on-the-fly measurements using one of the test functions, the light source or the power checker.
- Working with a smart device on which the EXFO Exchange mobile application is installed enables you to transfer jobs created with your Exchange account to your unit, and perform the associated tests. As soon as the tests are done, you can secure them to a cloud server and generate reports.

## **Technical Specifications**

To obtain this product's technical specifications, visit the EXFO website at *[www.exfo.com](http://www.exfo.com)*.

## Conventions

Before using the product described in this guide, you should understand the following conventions:



### **WARNING**

Indicates a potentially hazardous situation which, if not avoided, could result in *death or serious injury*. Do not proceed unless you understand and meet the required conditions.



### **CAUTION**

Indicates a potentially hazardous situation which, if not avoided, may result in *minor or moderate injury*. Do not proceed unless you understand and meet the required conditions.



### **CAUTION**

Indicates a potentially hazardous situation which, if not avoided, may result in *component damage*. Do not proceed unless you understand and meet the required conditions.



### **IMPORTANT**

Refers to information about this product you should not overlook.

## 2 **Safety Information**

### General Safety Information



#### **WARNING**

Do not install or terminate fibers while a light source is active. Never look directly into a live fiber and ensure that your eyes are protected at all times.



#### **WARNING**

The use of controls, adjustments and procedures, namely for operation and maintenance, other than those specified herein may result in hazardous radiation exposure or impair the protection provided by this unit.



#### **WARNING**

If the equipment is used in a manner not specified by the manufacturer, the protection provided by the equipment may be impaired.



#### **WARNING**

Use only accessories designed for your unit and approved by EXFO. For a complete list of accessories available for your unit, refer to its technical specifications or contact EXFO.



#### **CAUTION**

This product does not contain any user-serviceable components, except if indicated otherwise in this document. Any unauthorized product changes or modifications will invalidate warranty and all applicable regulatory certifications and approvals.



## **IMPORTANT**

Refer to the documentation provided by the manufacturers of any accessories used with your EXFO product. It may contain environmental and/or operating conditions limiting their use.



## **IMPORTANT**

When you see the following symbol on your unit , make sure that you refer to the instructions provided in your user documentation. Ensure that you understand and meet the required conditions before using your product.



## **IMPORTANT**

When you see the following symbol on your unit , it indicates that the unit is equipped with a laser source, or that it can be used with instruments equipped with a laser source. These instruments include, but are not limited to, modules and external optical units.















## **IMPORTANT**

Other safety instructions relevant for your product are located throughout this documentation, depending on the action to perform. Make sure to read them carefully when they apply to your situation.

## Other Safety Symbols on Your Unit

One or more of the following symbols may also appear on your unit.

Symbol	Meaning
	Direct current
	Alternating current
	The unit is equipped with an earth (ground) terminal.
	The unit is equipped with a protective conductor terminal.
	The unit is equipped with a frame or chassis terminal.
 or 	On (Power)
 or 	Off (Power)
	On/off (Power)
	Standby (Power)
	Fuse

## **Laser Safety Information**

Your instrument is in compliance with standard IEC 60825-1: 2014 + A11: 2021 and IEC 60825-1 Ed. 3.

Laser radiation may be encountered at the optical output port.

The following label indicates that a product contains a Class 1 source:

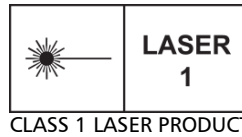

APPAREIL À LASER DE CLASSE 1

Complies with FDA performance standards for laser products except for conformance with IEC 60825-1 Ed. 3, as described in Laser Notice No. 56, dated May 8, 2019.

## Laser Safety Information (Units with VFL)

Your instrument is in compliance with standard IEC 60825-1: 2014 + A11: 2021 and IEC 60825-1 Ed. 3.

Laser radiation may be encountered at the optical output port.

The following label(s) indicate that the product contains a Class 2 source:

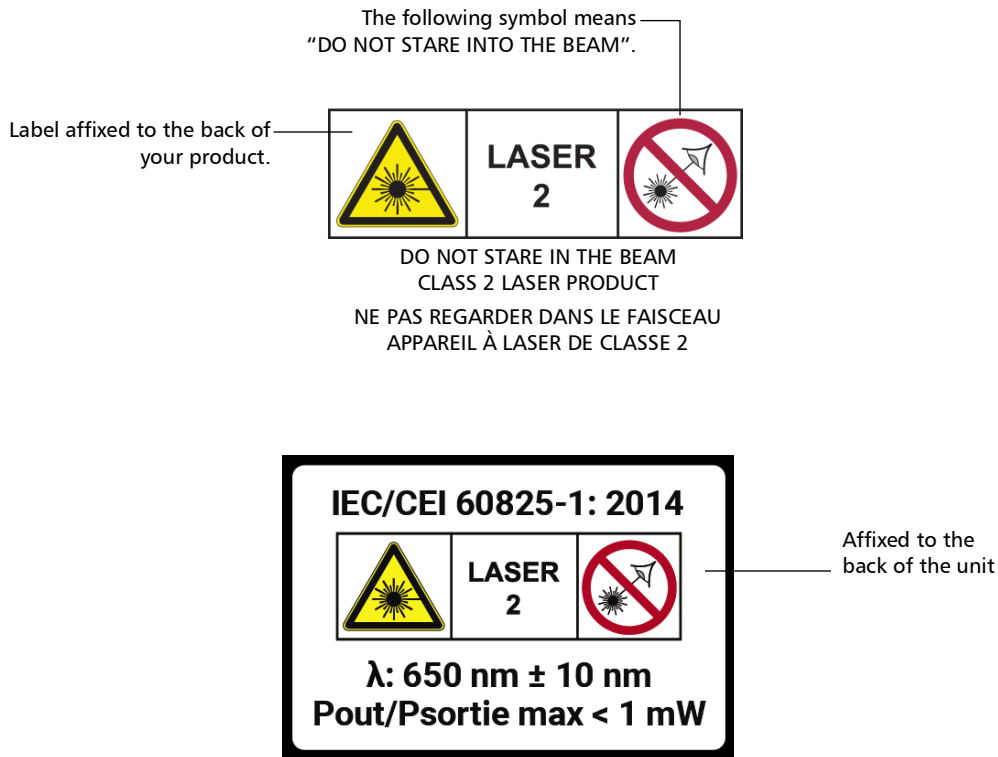

## Electrical Safety Information



### **WARNING**

If you need to ensure that the unit is completely turned off, disconnect the power cable and remove the battery. For more information on how to remove the battery, see the section about replacing the battery in this user documentation.



### **WARNING**

- Use the external power supply (USB power adapter) indoors only.
- Never connect the unit to a computer with the USB cable when it is used outdoors.
- Unless otherwise specified, all interfaces are intended for connection to ES1 circuits only.
- Use only the listed and certified USB power adapter provided by EXFO with your unit. It provides reinforced insulation between primary and secondary, and is suitably rated for the country where the unit is sold.



### **CAUTION**

- Position the unit so that the air can circulate freely around it.
- When you use the unit outdoors, ensure that it is protected from liquids, dust, direct sunlight, precipitation, and full wind pressure.



### **CAUTION**

The use of voltages higher than those indicated on the label affixed to your unit may damage the unit.

<b>Equipment Ratings</b>	
<p>Temperature</p> <ul style="list-style-type: none"> <li>➤ Operation</li>   <li>➤ Storage</li> </ul>	<ul style="list-style-type: none"> <li>➤ unit powered by battery: -10 °C to 45 °C (14 °F to 113 °F)<sup>1</sup></li> <li>➤ unit connected to AC power (with USB power adapter): 0 °C to 40 °C (32 °F to 104 °F)<sup>2</sup></li> <li>➤ unit – short-term storage (without battery)<sup>3</sup>: -40 °C to 70 °C (-40 °F to 158 °F)</li> <li>➤ unit – short-term storage (with battery)<sup>3</sup>: -40 °C to 60 °C (-40 °F to 140 °F)</li> <li>➤ unit – long-term storage<sup>4</sup>: 10 °C to 35 °C (50 °F to 95 °F)</li> </ul>
<p>Relative humidity<sup>5</sup></p>	<ul style="list-style-type: none"> <li>➤ unit: ≤ 93 % non-condensing</li> <li>➤ USB power adapter: 10 % to 90 % non-condensing</li> </ul>
<p>Maximum operation altitude</p>	<ul style="list-style-type: none"> <li>➤ 2000 m (6562 ft) (unit connected to external power source)</li> <li>➤ 5000 m (16405 ft) (unit operated from battery)</li> </ul>

Equipment Ratings	
Pollution degree	<ul style="list-style-type: none"> <li>➤ 2 (unit connected to external power source)</li> <li>➤ 3 (unit operated from battery)<sup>6</sup></li> </ul>
Overvoltage category	<ul style="list-style-type: none"> <li>➤ unit: I</li> <li>➤ USB power adapter: II</li> </ul>
Measurement category	Not rated for measurement categories II, III, or IV
Input power <sup>7</sup>	Unit: 5 - 9 V ---; 15 W <sub>MAX.</sub> (via USB-C) USB power adapter: <ul style="list-style-type: none"> <li>➤ AC Input power: 100 - 240 V ~; 50/60 Hz; 0.5 A</li> <li>➤ DC Output power:               <ul style="list-style-type: none"> <li>❖ 5.0 V --- ; 3.0 A</li> <li>❖ 9.0 V --- ; 2.22 A</li> <li>❖ 12.0 V --- ; 1.67 A</li> </ul> </li> </ul>

1. When the unit is used at an altitude of 5000 m, the maximum operating temperature is 27 °C (80.6 °F).
2. When the ambient temperature is below 0 °C (32 °F) or when it reaches or exceeds about 40 °C (104 °F), the main battery can either charge more slowly than usual, or not charge at all, depending on the internal temperature of your unit.
3. Short-term storage corresponds to the storage of the unit for a maximum of 48 hours.
4. Long-term storage corresponds to the storage of the unit for more than three months.
5. Measured in 0 °C to 31 °C (32 °F to 87.8 °F) range, decreasing linearly to 50 % at 40 °C (104 °F).
6. Equipment must be normally protected against exposure to direct sunlight, precipitation and full wind pressure.
7. Not exceeding ± 10 % of the nominal voltage.



## CAUTION

The device is compliant with USB 2.0 and USB 3.0 power specifications for input current and voltage regulation and meets USB On-the-Go (OTG) operation power rating specification with constant current limit up to 3.2 A.

# 3

## Getting Started With Your AXS Handheld OTDR

### Turning on Your Unit

When you turn on the unit for the very first time, a wizard is displayed, enabling you to set the operation language, read and accept the EXFO license agreement, and set other regional settings (see *Configuring Your Unit at First Startup* on page 21 for more information).

**Note:** *The settings you modify at startup can be modified later if necessary.*

#### **To turn on the unit:**

Press the on/off button until the unit beeps once. Its LED will light up and remain lit during the whole startup process (until the splash screen is displayed).

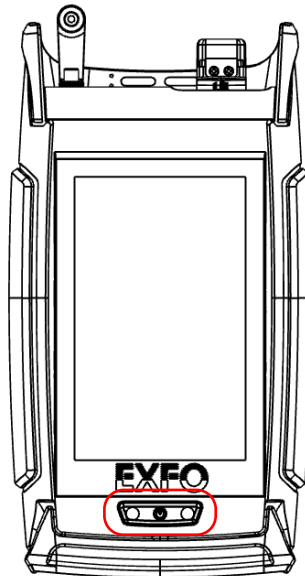

### Turning off Your Unit

Unless specified otherwise in this documentation, the settings you configure on your unit are kept in memory even when you turn the unit off.

There are several ways to turn off the unit, including the following:

- *Sleep*: keeps the unit's status information in memory (RAM). The next time you turn your unit on, you will quickly return to your work environment (running applications will still be running). If you intend to leave your unit in sleep mode for more than a few days, you should perform a shutdown instead to save battery power.
- *Shutdown*: completely cuts power to the test instruments and unit; the unit will perform a complete restart routine the next time you use it. You should perform a shutdown if you do not intend to use your unit for a long time.

**Note:** *Should the unit ever stop responding, you can force a hardware reset by pressing and holding down the on/off button for up to 20 seconds. To restart your unit, release the on/off button, and then press it again as you would normally do to start your unit. A hardware reset will also reset the clock, so you must set it up again as explained in Adjusting the Date, Time and Time Zone on page 45.*

#### **To exit the sleep mode and resume your work:**

Press the on/off button.

#### **To turn off the unit completely (shutdown):**

1. Press and hold the on/off button for about three seconds.
2. The unit will ask if you want to power off the unit or restart it. Select **Power off** to confirm your choice.

## Configuring Your Unit at First Startup

The first time you turn on the unit, a wizard is displayed, enabling you to set the operation language, set the date and time, and read and accept the EXFO license agreement.

**Note:** *You can change the regional parameters and language later if necessary.*

### **To configure your unit at first startup:**

1. If it is not already done, turn on the unit.
2. When the wizard appears on-screen, tap anywhere to access the first window.

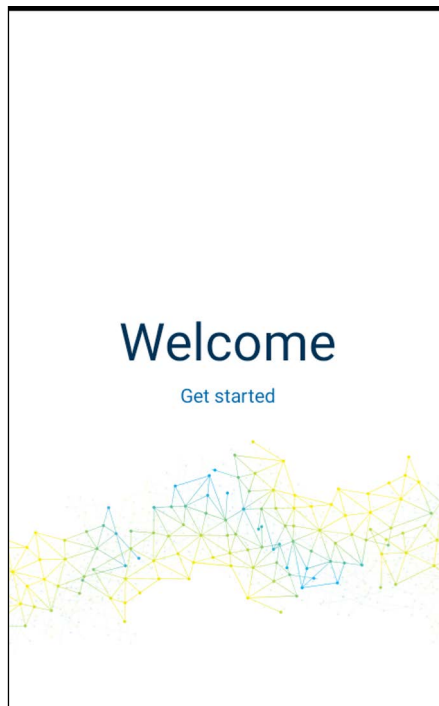

3. Select the desired operation language.

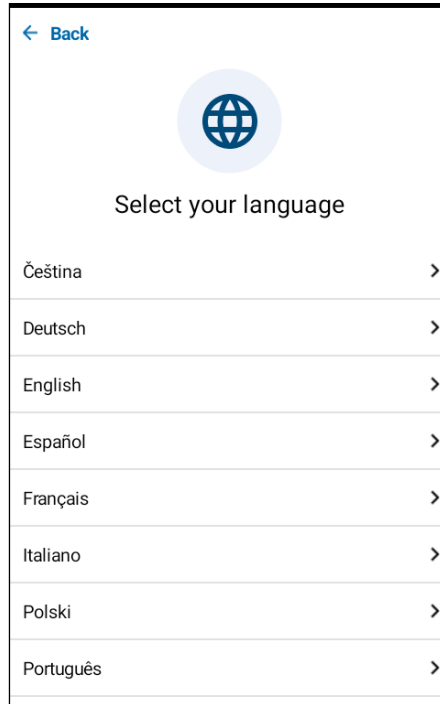

4. Select the region related to your language. Tap **Next** to proceed to the next page.

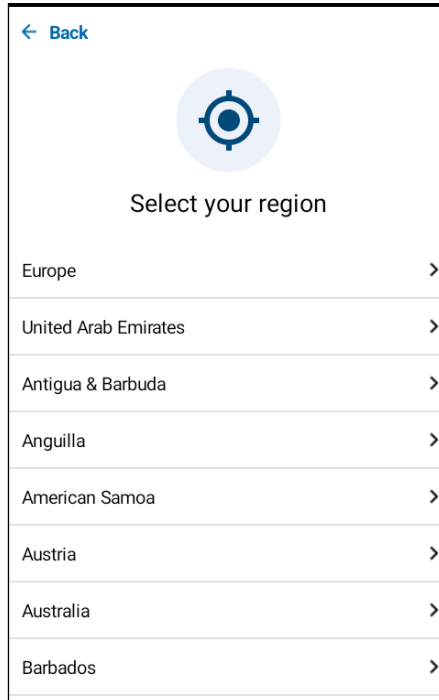

5. Set the Wi-Fi network by tapping on the screen and entering the required information.

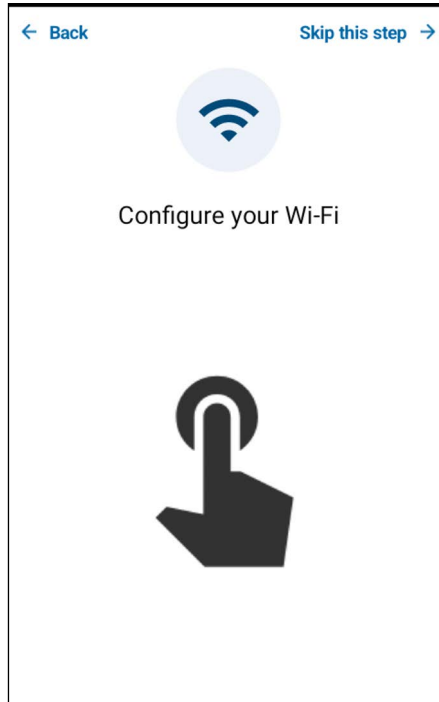

6. Set the date and time by tapping on the screen and selecting the desired values.

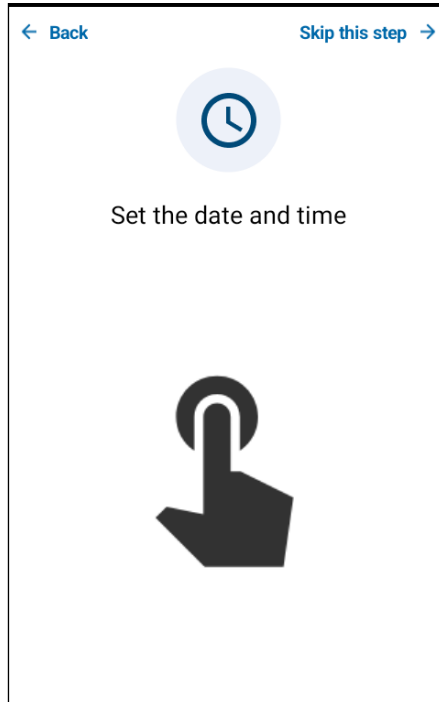

7. Set the measurement units you want to use for your measurements.

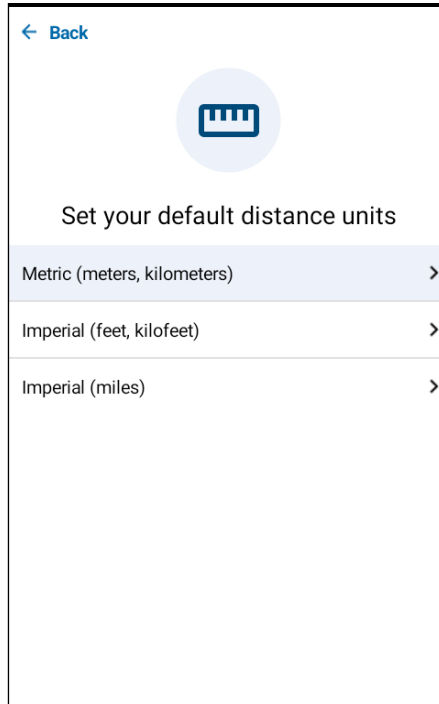

### 8. Read and accept the EXFO license agreement.

← Back

### Software Agreement

EXFO Licensed Software Authorized User License Agreement

This EXFO Licensed Software Authorized User License Agreement ("EULA") shall apply to any Customer and its Authorized Users, for all its request for quotations and purchase orders, EXFO order acknowledgements and invoices and any delivery of Licensed Software by EXFO, for which there is no separate license agreement between you and the manufacturer or owner of the software, together with EXFO's Standard Terms, available at [www.exfo.com/en/how-to-buy/sales-terms-conditions](http://www.exfo.com/en/how-to-buy/sales-terms-conditions) or from EXFO upon request, which are an integral part of this EULA.

IMPORTANT: BY ORDERING, INSTALLING, DOWNLOADING, OR USING THE LICENSED SOFTWARE OR OTHERWISE PROCEEDING WITH ANY TRANSACTION AFTER RECEIPT OF THE EULA, OR BY CLICKING ON THE ACCEPT BUTTON OR SIMILAR BUTTON, YOU, AS THE INDIVIDUAL OR SINGLE ENTITY ACQUIRING THE LICENSED SOFTWARE, OR AS THE AUTHORIZED USER SIGNIFY THAT YOU HAVE READ AND ACCEPTED THE TERMS AND CONDITIONS OF THIS EULA AS OF THE DATE ON WHICH YOU FIRST ORDER THE LICENSED SOFTWARE, INSTALL, DOWNLOAD, USE OR CLICK THE ACCEPT BUTTON (THE "EFFECTIVE

**I Agree with the terms and conditions**

You are now ready to start working with your AXS Handheld OTDR.

### Understanding the Main Window

The OTDR view can be seen as the starting point of the application where you can perform measurements in different modes and navigate through the results, and even redo measurements when necessary. If your unit has wireless capabilities, it provides information on many elements such as the Bluetooth connection, Wi-Fi connection and signal strength.

From the main window, you can also open the three-line menu to access the job menu and settings menu.

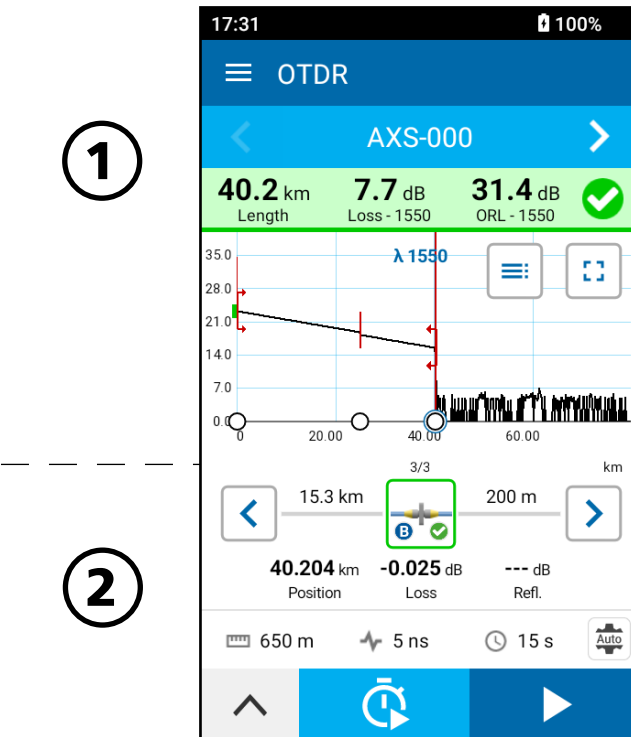

# Getting Started With Your AXS Handheld OTDR

## Understanding the Main Window

1

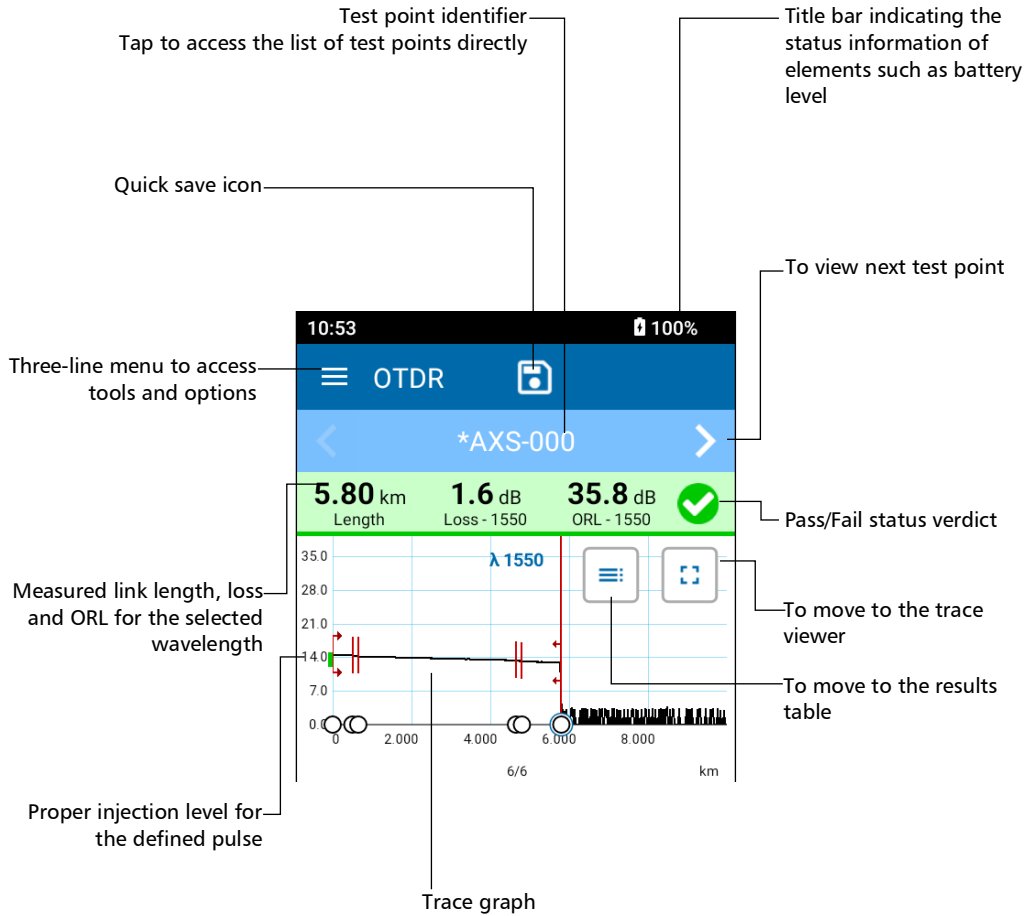

# Getting Started With Your AXS Handheld OTDR

## Understanding the Main Window

2

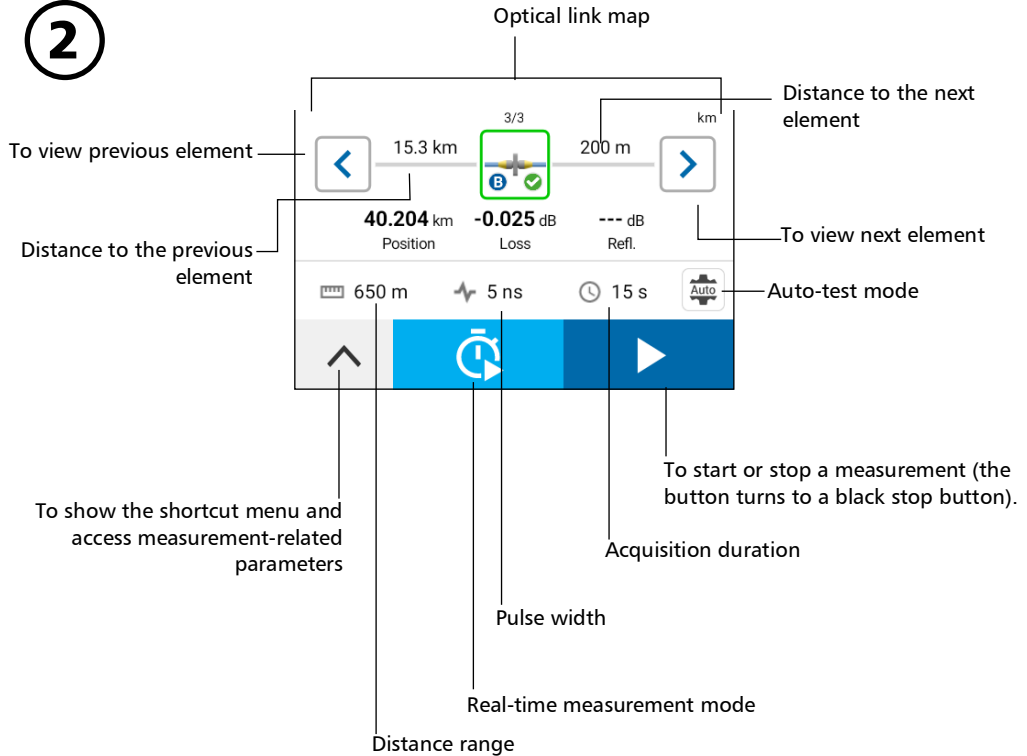

## Cleaning and Connecting Optical Fibers



### CAUTION

To ensure maximum power and to avoid erroneous readings:

- Always inspect fiber ends and make sure that they are clean as explained below before inserting them into the port. EXFO is not responsible for damage or errors caused by bad fiber cleaning or handling.
- Ensure that your patchcord has appropriate connectors. Joining mismatched connectors will damage the ferrules.

#### *To connect the fiber-optic cable to the port:*

1. Inspect the fiber using a fiber inspection scope (or probe). If the fiber is clean, proceed to connecting it to the port. If the fiber is dirty, clean it as explained below.
2. Clean the fiber ends as follows:
  - 2a. Gently wipe the fiber end with a lint-free swab dipped in optical-grade liquid cleaner.
  - 2b. Use a dry swab to dry the connector completely.
  - 2c. Visually inspect the fiber end to ensure its cleanliness.

3. Carefully align the connector and port to prevent the fiber end from touching the outside of the port or rubbing against other surfaces.

If your connector features a key, ensure that it is fully fitted into the port's corresponding notch.

4. Push the connector in so that the fiber-optic cable is firmly in place, thus ensuring adequate contact.

If your connector features a screw sleeve, tighten the connector enough to firmly maintain the fiber in place. Do not overtighten, as this will damage the fiber and the port.

**Note:** *If your fiber-optic cable is not properly aligned and/or connected, you will notice heavy loss and reflection.*

EXFO uses good quality connectors in compliance with EIA-455-21A standards.

To keep connectors clean and in good condition, EXFO strongly recommends inspecting them with a fiber inspection scope (or probe) before connecting them. Failure to do so may result in permanent damage to the connectors and degradation in measurements.

# 4

## Setting up Your Unit

### Adjusting Brightness

You may want to adjust the display brightness yourself to better fit your work environment or preferences.

You may also want to reduce the display brightness to save battery power (the higher the brightness level, the higher the power consumption).

The brightness value is kept in memory even when you turn the unit off.

#### ***To adjust the display brightness from the Setup menu:***

1. From the main menu, tap  .
2. Scroll down to the **Device settings** section.
3. Tap **Display**.

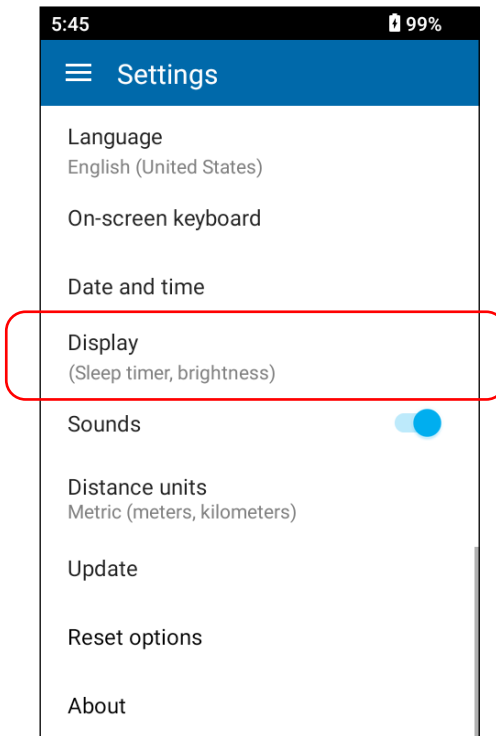

4. Tap **Brightness level** and adjust the value until the screen appearance is to your liking.

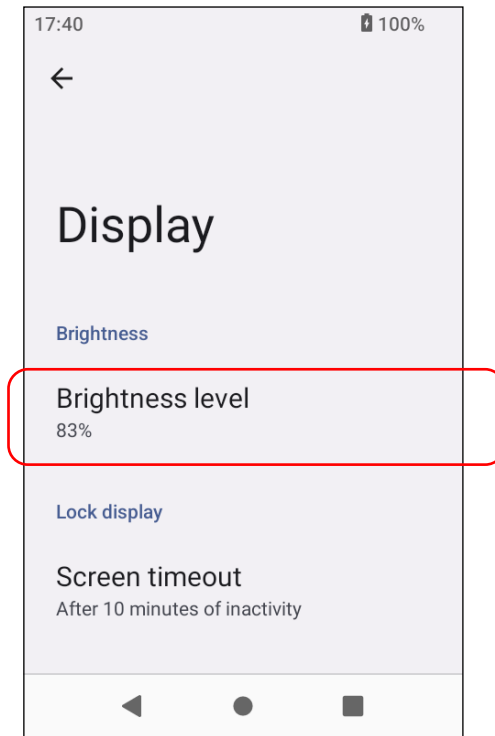

The new brightness level is taken into account immediately.

**To adjust the brightness level from the main window:**

1. Hold your finger to the screen and drag it down to make the slider appear.

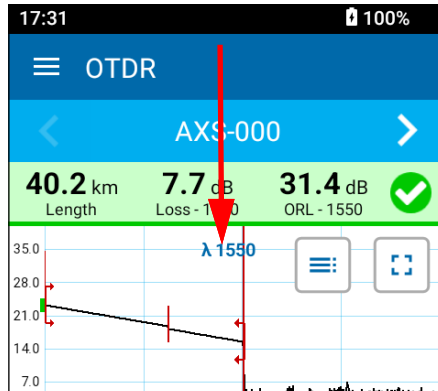

2. Change the brightness level as needed.

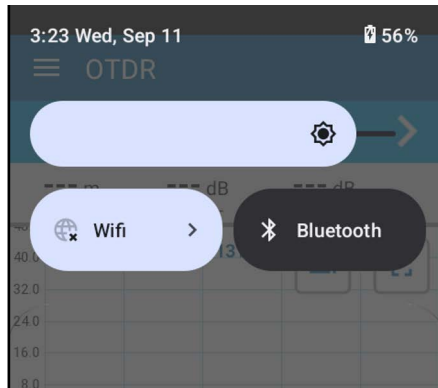

## Enabling or Disabling Sound Notifications

By default, your unit emits a sound at the end of a measurement and when the power checker detects a tone.

You can disable the sound notifications if you prefer. Your preference is kept in memory even when you turn the unit off.

**To enable or disable the sound notifications on your unit:**

1. From the main menu, tap .
2. Scroll down to the **Device settings** section.
3. With the **Sounds** toggle, enable or disable the sound notifications.

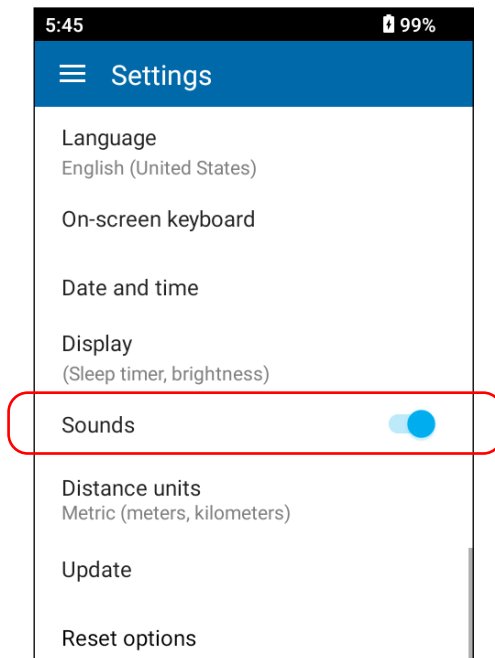

The new value is taken into account immediately.

## Selecting the Language of Operation

You may display the user interface in one of the available languages. English is the default language.

**Note:** *The value is kept in memory even when you turn the unit off.*

### To add a language to the list:

1. From the main menu, tap .
2. Scroll down to the **Device settings** section.
3. Tap **Language**.

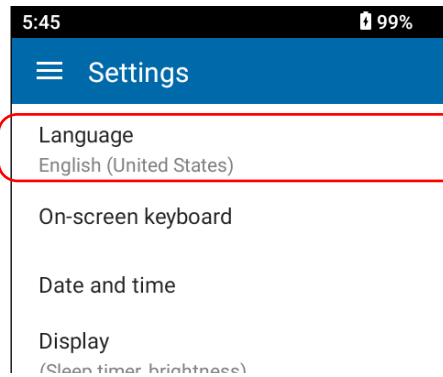

**4. Tap Add a language.**



- 5.** Tap on the desired language in the list, then select the region.

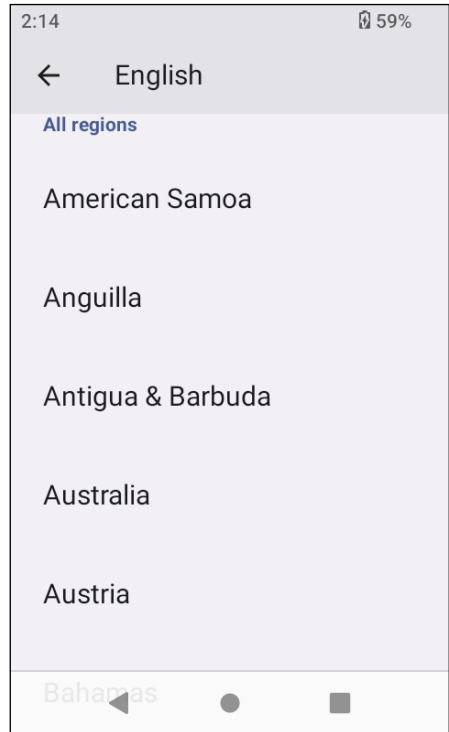
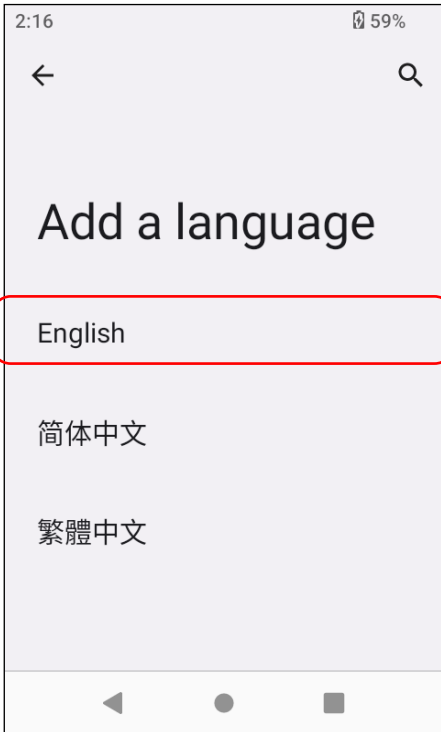

The language is added to the list.

#### To select a new interface language:

1. From the main menu, tap .
2. Scroll down to the **Device settings** section.
3. Tap **Language**.

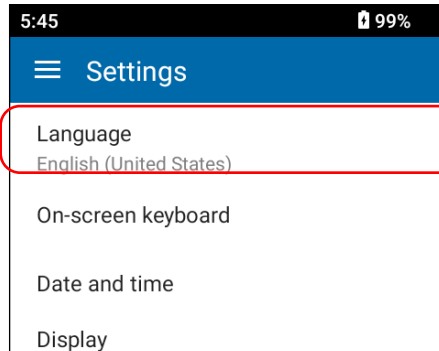

4. Tap and drag the = next to the desired language to bring your selection to the top of the list. The change is updated automatically.



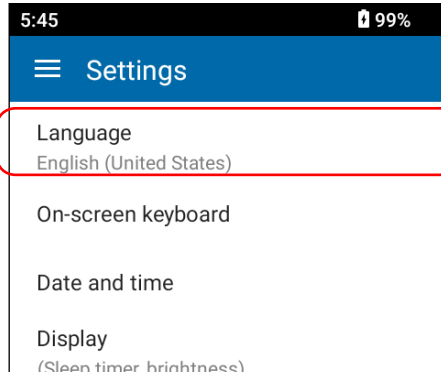

#### To remove a language from the list:

1. From the main menu, tap .
2. Scroll down to the **Device settings** section.
3. Tap **Language**.

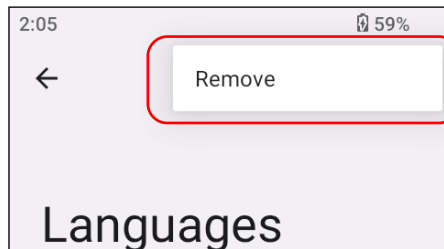

4. Tap the ... menu, then select **Remove**.



5. Select the language or languages you want to delete, then tap  and confirm your choice.



## Selecting the On-Screen Keyboard

You can select which type of keyboard to use in the application:

**To select the on-screen keyboard type:**

1. From the main menu, tap .
2. Scroll down to the **Device settings** section.
3. Tap **On-screen keyboard**.

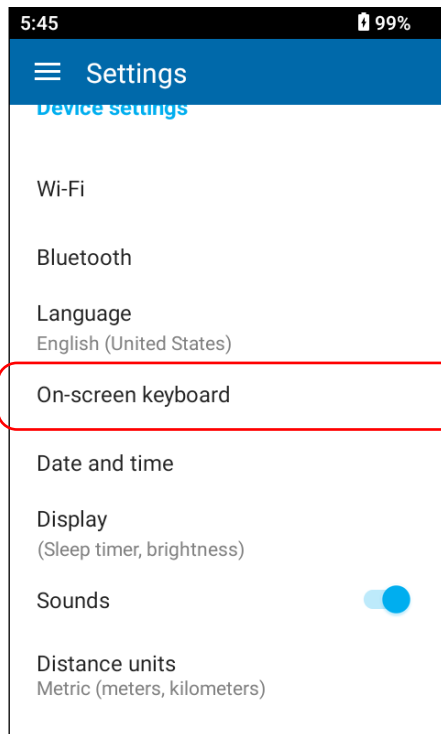

4. Select the keyboard to use among the available choices.

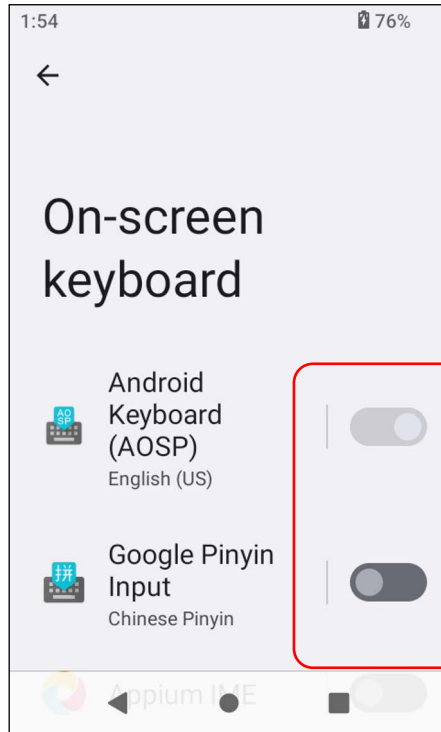

## Adjusting the Date, Time and Time Zone

The time is displayed in the title bar. When saving results, the unit also saves the corresponding date and time.

By default, the time is expressed in a 12-hour format (AM/PM), but you can select a 24-hour format if you prefer.

### To modify the date format:

1. From the main menu, tap .
2. Scroll down to the **Device settings** section.
3. Tap **Date and time**.

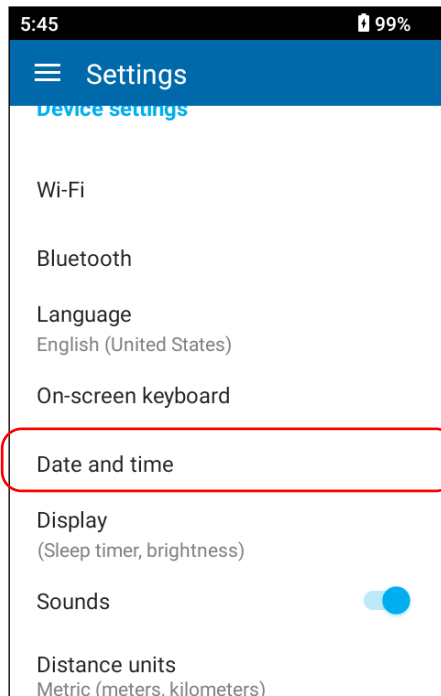

4. Enter the date and time as needed.

5. You can also select the time zone by tapping on the option and selecting the desired information.

**Note:** *If you experience trouble connecting to the Wi-Fi, the automated date might become inaccurate*

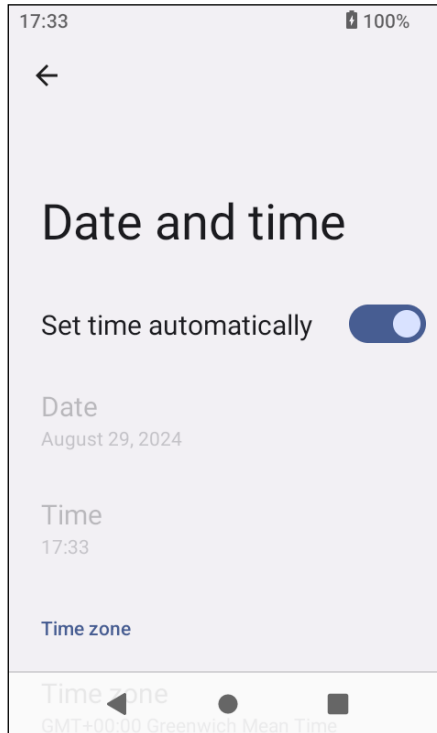

The new time format is taken into account immediately.

## Selecting the Distance Units

You can select the measurement units that your unit will use to display distance and length values.

By default, the unit uses metric distance units (meters and kilometers), but you can change for imperial units (feet, kilofeet and miles) if you prefer.

**Note:** *Values of less than 1 kilometer or 1 kilofeet will be expressed, respectively, in meters or feet for more precision.*

**Note:** *The measurement units used on your AXS Handheld OTDR are independent from those used in cloud-based jobs. This means that you may have to make changes to ensure consistency in the selected measurement units.*

The value that you set is kept in memory even when you turn the unit off.

### **To select the distance units:**

1. From the main menu, tap  .
2. Scroll down to the **Device settings** section.

**3. Tap **Distance units**.**

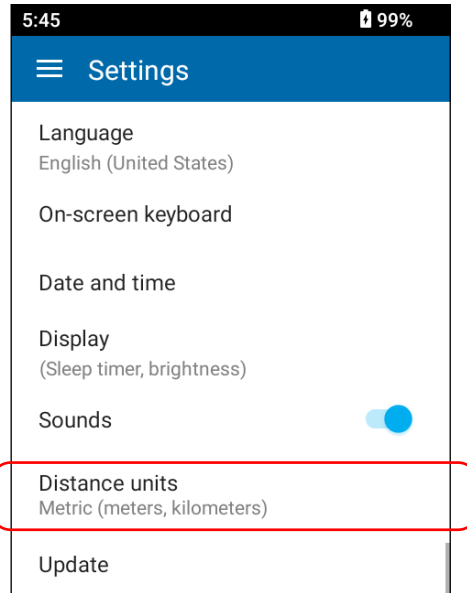

**4. Select the desired distance units.**

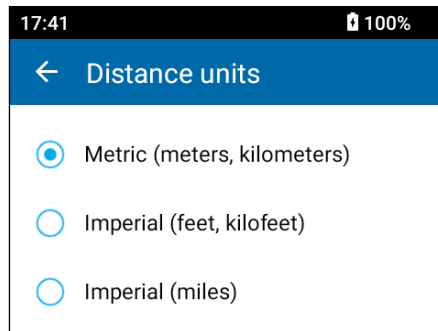

The new value is taken into account immediately.

## Configuring the Sleep Mode

To help you get the optimum performance out of your unit, it comes with a predefined set of parameters to manage power.

When you do not use your unit for a while, it will go into sleep mode automatically to save power (see *Turning off Your Unit* on page 20).

**Note:** *Any data transfer that was underway will continue normally unless the battery level becomes too low. In the event of a low battery, there would be no data loss as no data is erased from your unit until the transfer of all data is complete (to the EXFO Exchange mobile application or to the cloud server if your unit has wireless capabilities).*

By default, the duration after which the unit goes into sleep mode is ten minutes, but you can select another value.

The value that you set is kept in memory even when you turn the unit off.



### IMPORTANT

- If you intend to leave your unit in sleep mode for more than a few days, you should turn it off (shutdown) to save battery power. If your unit is in sleep mode and the battery level becomes too low, the unit will not go into shutdown mode automatically.
- The unit will not enter sleep mode while you perform tests.
- To avoid a possible battery drainage, do not forget to stop the source manually if you have deactivated its timer. Also, do not forget to close the power checker page when you have finished your work and turn off the VFL if you are not using it.

**To configure the duration after which the unit enters sleep mode:**

1. From the main menu, tap  .
2. Scroll down to the **Device settings** section.
3. Tap **Display**.

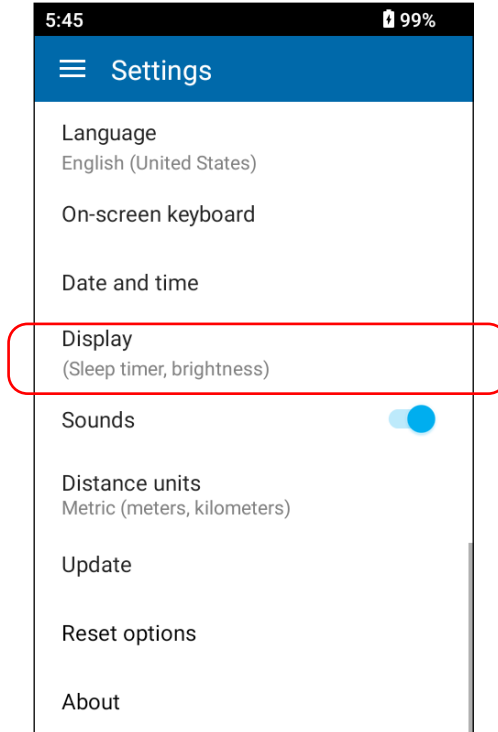

4. Tap **Screen timeout**, then select the desired number of minutes.

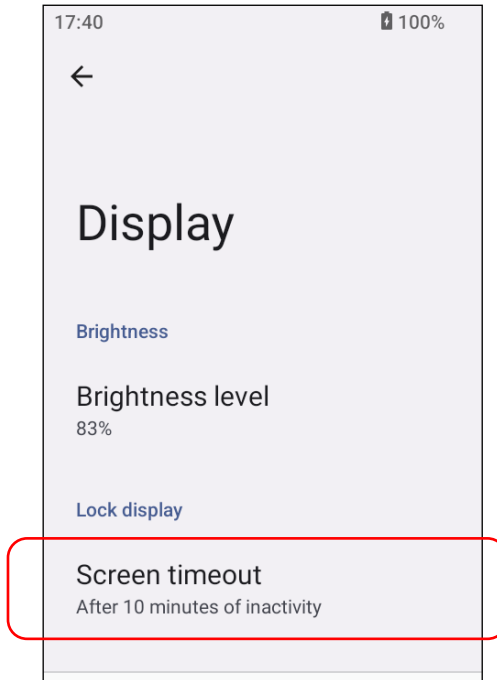

The new value is taken into account immediately.

## Selecting Test Wavelengths

You can select the wavelengths you want to use for your measurements. The selection of the wavelengths is kept in memory when you turn off the device.

**To select test wavelengths:**

1. From the main menu, tap .
2. Under **OTDR**, tap **Wavelengths**.

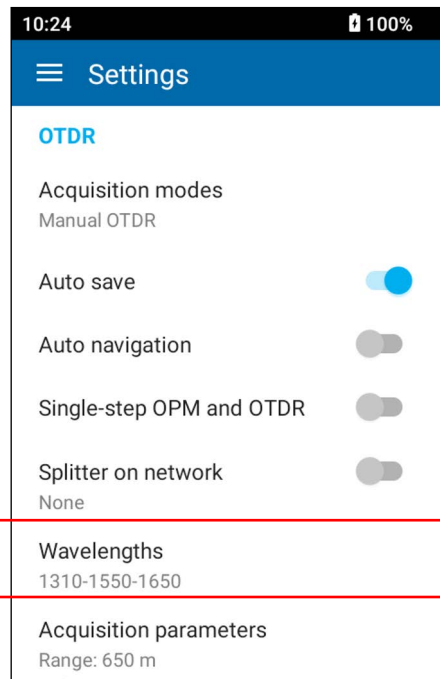

3. Select the wavelengths you want to use for your measurements.

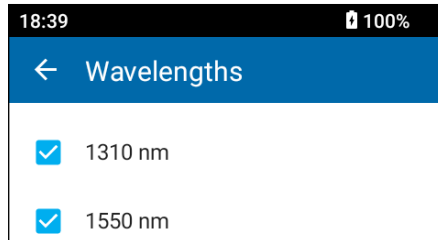

The selection will be taken into account for the next measurement.

**Note:** *The wavelength selection window is also available from the shortcut menu in the main OTDR window.*

## Setting Power Checker Thresholds

Your AXS Handheld OTDR can measure the power of a link and give you a pass or fail status based on thresholds that you set for all wavelengths at once, or you can set thresholds for individual wavelengths. If a tone is detected, you will see it in the power checker window as well.

### To set the power checker thresholds:

1. From the main menu, tap .
2. Under **Power checker**, tap **Thresholds**.

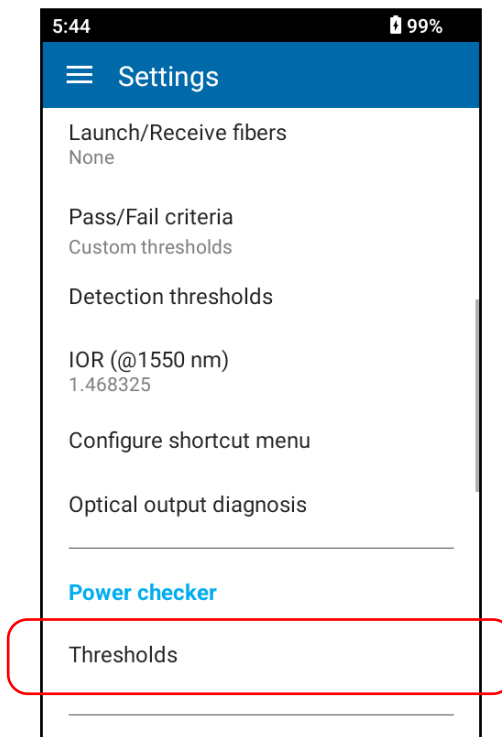

**Note:** You can access the threshold page by tapping on the thresholds in the Power Checker page as well.

3. In the **Power checker thresholds** page, select whether you want the thresholds to apply to all wavelengths, or you can select specific minimum and maximum thresholds individually.
4. To enable a threshold, tap the toggle. To change the value, tap on the threshold, then enter the desired value.

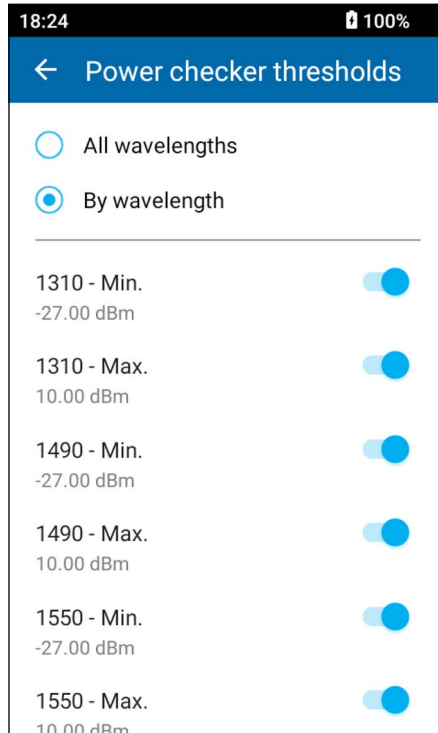

## Enabling or Disabling Auto Save

When performing measurements, you can define the unit's behavior after the measurement process is complete. You can either have the unit save each measurement automatically or only save the measurements that you wish to keep by using the quick save feature.

Enabling or disabling the auto save feature applies to both local and cloud-based jobs. By default, the auto save feature is enabled. Your preference is kept in memory when you turn the unit off.

### To enable or disable auto save:

1. From the main menu, tap .
2. Scroll down to the **OTDR** section.
3. Enable or disable the auto save with the corresponding toggle.

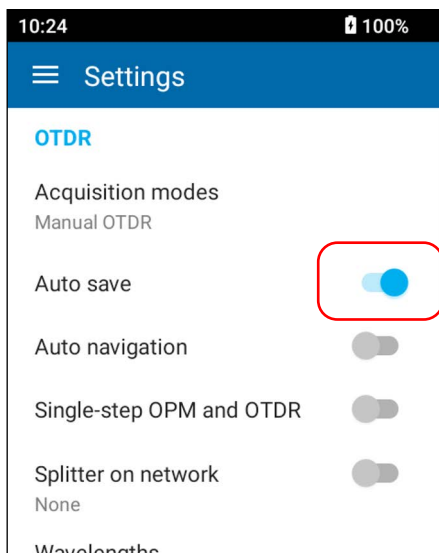

The selection will be taken into account for the next measurement.

**Note:** You can also enable or disable this feature from the shortcut menu in the main OTDR window if you have enabled it, see *Configuring the Shortcut Menu on page 70 for details.*

## Enabling or Disabling Auto Navigation

The auto navigation feature lets your unit proceed to the next available test point in a job once the measurement is saved. Enabling or disabling the auto navigation feature applies to both local and cloud-based jobs.

By default, the auto navigation feature is disabled. Your preference is kept in memory when you turn the unit off.

### **To enable or disable auto navigation:**

1. From the main menu, tap .
2. Scroll down to the **OTDR** section.
3. Enable or disable the auto navigation with the corresponding toggle.

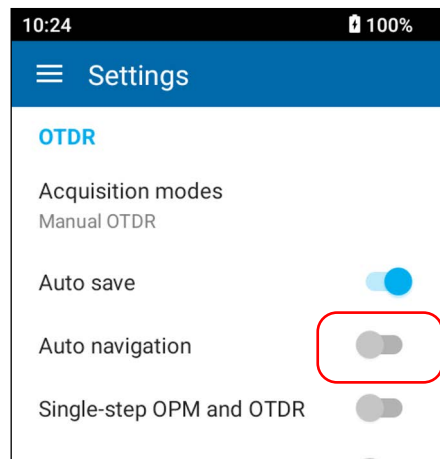

The selection will be taken into account for the next measurement.

## Selecting an Acquisition Mode (AXS-130-SM7/SM8 Models Only)

You can use various Optimodes to perform your test. These acquisition modes are designed for specific purposes:

- **Manual OTDR:** Standard single-pulse OTDR acquisition. Choose the range, pulse, duration and wavelength(s) for your test.
- **PON characterization:** ONT toward OLT full-link analysis. Choose the wavelength and splitter configuration
- **PON last mile towards ONT:** Test from sokutter towards the ONT (splitter > ONT). Characterizes the link and validates the ONT connection. Available only for the 1650 nm wavelength.
- **ONT to splitter:** Test from the ONT towards the splitter (ONT > splitter). Characterizes the links up to the first splitter, including splitter continuity detection. Choose the splitter ratio to detect. Available only for the 1625 nm wavelength.
- **SFP safe mode:** SFT safe mode P2P measurement on active network for short links (typically less than 10 km). Safe mode applies to real-time measurement. Available only for the 1625 nm wavelength.

#### To select an acquisition mode:

1. From the main menu, tap .
2. Scroll down to the **OTDR** section, then tap **Acquisition modes**.

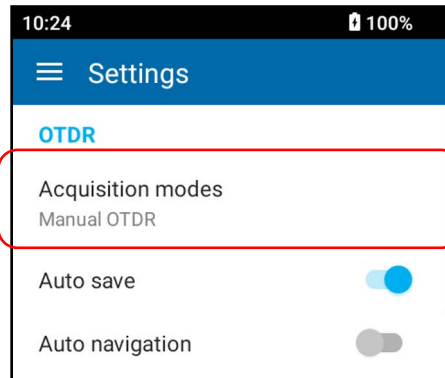

3. Select the mode you need.

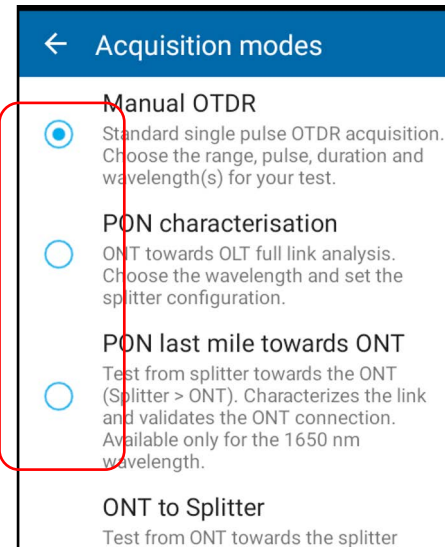

The new mode will apply to the next acquisition.

## **Working With Launch and Receive Test Fibers**

Launch and receive fibers are used to characterize respectively the first and last connectors in your fiber under test. A launch fiber allows the AXS Handheld OTDR to recover after the test pulse is sent into the fiber, while a receive fiber is used to enable measurements of the connector (loss and reflectance) at the end of the fiber under test.

When you perform tests with your unit, you connect a launch fiber between your unit and the fiber under test. You can also connect a receive fiber at the end of the fiber under test. By default, the fiber span includes the receive fiber (but not the launch fiber).

When you define the length of the launch fiber, the application sets the fiber link start at the beginning of the fiber under test. The link start becomes event 1 and its distance reference becomes 0. It allows to characterize the first connector at the beginning of the fiber. The application will include the loss caused by the link start event in the displayed values. The link start event will also be taken into account when determining the status (pass/fail) of connector loss and reflectance.

When the receive length is mentioned, the application finds the event which is characterized as the end of fiber. The span end is moved according to a value corresponding to the specified receive fiber length (except for continuous or end of analysis events). When the span end is positioned, an event should be near the new position of the span end. If no event is found, the application will automatically add an event where there should be one. Events excluded from the fiber span do not appear in the trace display.

If the launch and receive fibers are not defined, they will appear as if they were part of the fiber under test (fiber span). The cumulative loss is calculated for the defined fiber span only.

By default, the use of launch and receive fibers is disabled, but you can enable it and specify the lengths of the fibers you intend to use. The length of both fibers is set to 20 meters by default, but you can change it if your pulse widths are larger than 100 ns to avoid the merge of it with the fiber under test for result interpretation.

**Note:** For APC connectors, EXFO recommends 20 m, whereas the minimum for UPC connectors should be 60 m. The fiber must have at least one APC connector to be able to connect it to the AXS.

You can also change measurement units from meters to feet if you prefer. All your settings are kept in memory even when you turn off the unit.

The launch and receive fibers and their connectors should always be in good condition. The connectors should also be clean before using the fibers.

Refer to the technical specifications of your unit to have a complete list of all the launch and receive fibers available.

### To configure the launch and receive fiber lengths:

1. From the main menu, tap .
2. From the **OTDR** section, tap **Launch/Receive fibers**.

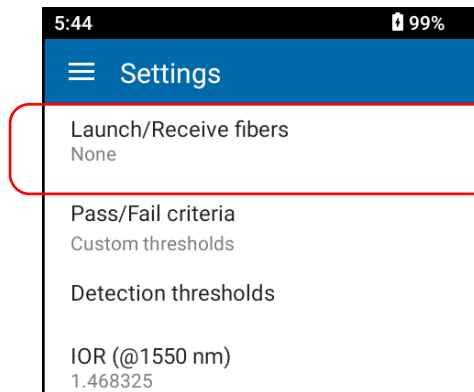

3. If necessary, activate the feature with the corresponding toggle.

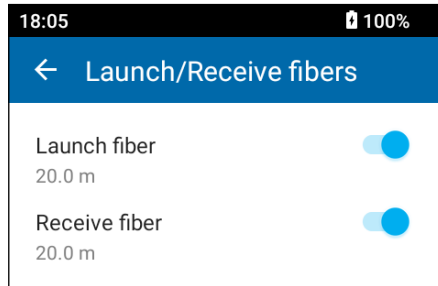

4. Under the desired test fiber, tap the displayed length to edit it. Select the length of the cable you want to use for your measurement. If you have selected **Custom**, enter the length with the numeric keypad.

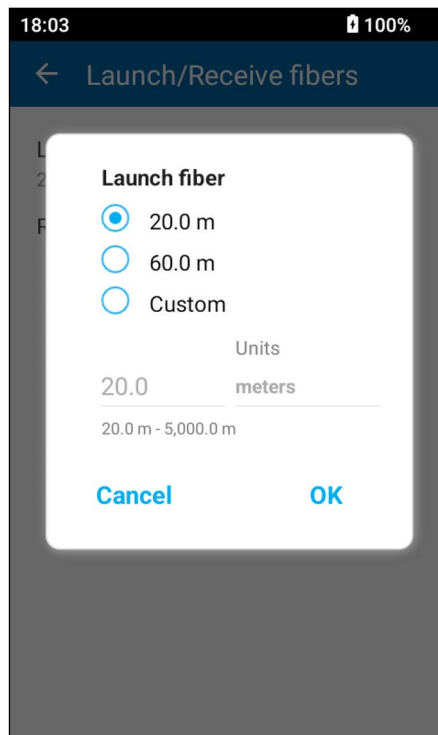

5. If necessary, change the distance units.
6. Tap **OK** to confirm.

The new selection is taken into account for the next measurement.

*You can also access the launch and receive fiber settings page from the shortcut menu in the main OTDR page.*

## Working With Pass/Fail Thresholds

As soon as a measurement is complete, the application displays a status:

- Pass
- Fail
- Unknown

The application displays a Pass/Fail status when thresholds are applied. It is displayed in the Link Results area and it can be pass, fail, or unknown. See *Working With Link Summary* on page 130 for details.

**To configure thresholds:**

1. From the main menu, tap  .
2. Under **OTDR**, tap **Pass/Fail criteria**.

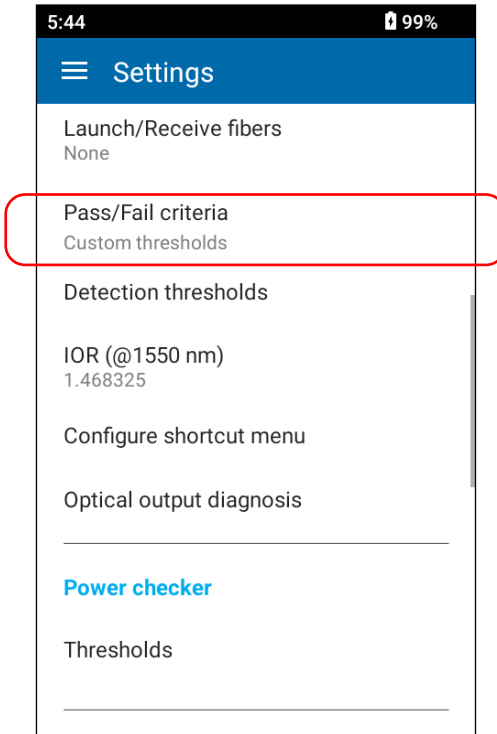

3. If necessary, activate the threshold with the toggle button.

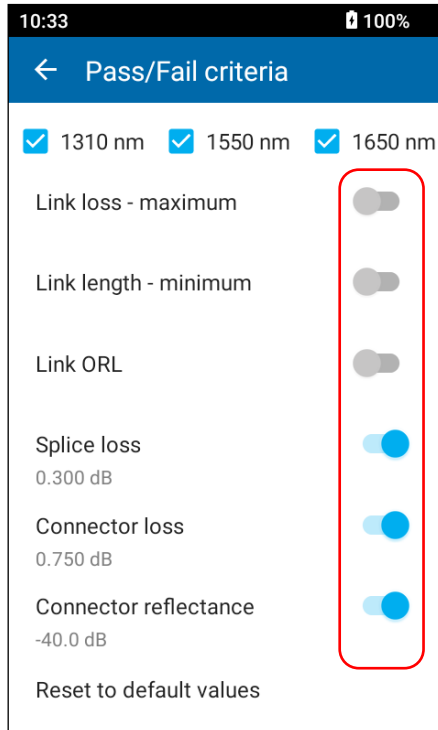

4. Tap the threshold you want to modify.

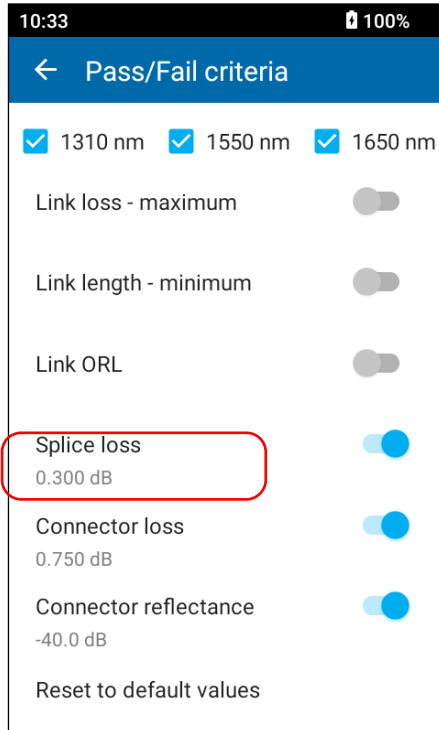

5. Enter a new value.

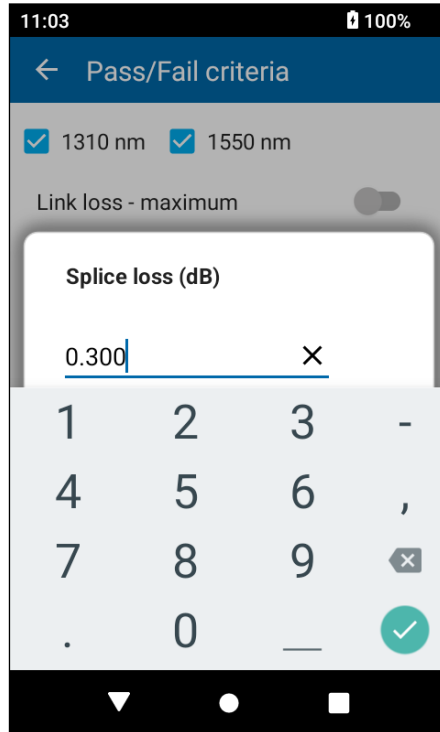

6. Tap **OK** to return to the **Pass/Fail criteria** page.
7. Repeat steps 4 and 5 for each criterion you want to change.

The new thresholds are taken into account for the next measurement.

**Note:** You can also access the pass/fail threshold page from the shortcut menu in the main OTDR window.

## Configuring the IOR Value

Having the proper index of refraction (IOR) is crucial for all measurements associated with distance (element position, total length, etc.). By doing so, you ensure that the distances are more accurate for your measurements.

You can edit the IOR value associated with the 1550 nm wavelength only. The unit automatically finds the corresponding IOR value for other wavelengths.

IOR is provided by the cable or fiber manufacturer.

### To configure the IOR value:

1. From the main menu, tap .
2. Under **OTDR**, tap **IOR (@1550 nm)**.

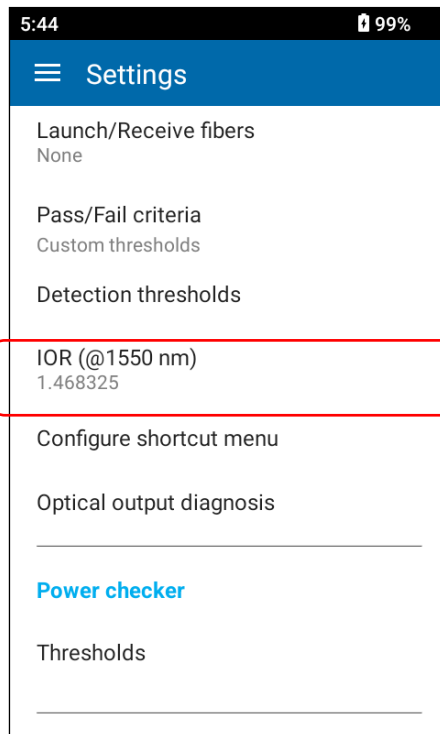

3. Enter the new value.

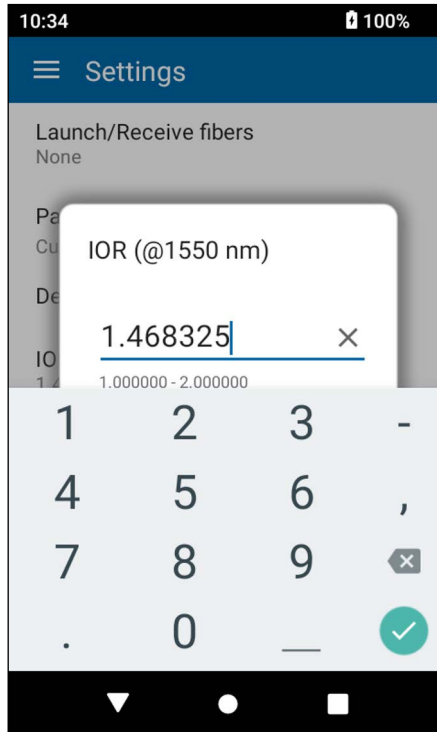

4. Tap **OK** to confirm the new value and return to the **Settings** page.

The new value will be taken into account for the next measurement.

**Note:** *If you want to revert to the default value, tap the X at the right of the field*

## Configuring the Shortcut Menu

You can configure the shortcut menu that is accessible from the OTDR main window. From this menu, you can select certain functionalities you wish to configure directly from the shortcut menu, such as:

- Auto save
- Auto navigation
- Wavelengths
- Launch/Receive fibers
- Pass/Fail criteria

### To configure the shortcut menu:

1. From the main menu, tap  .
2. Under **OTDR**, tap **Configure shortcut menu**.

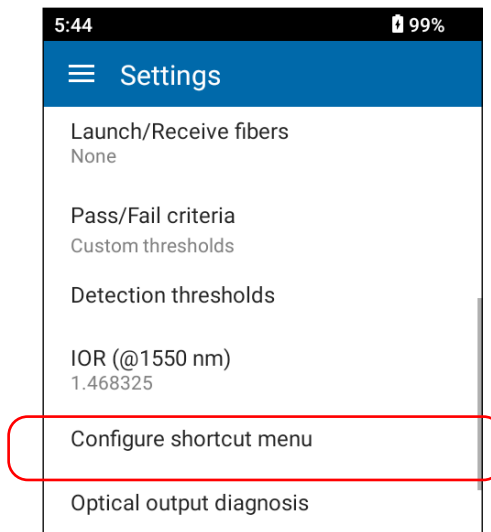

3. Select the item(s) you want to be able to access from the shortcut menu in the OTDR main window.

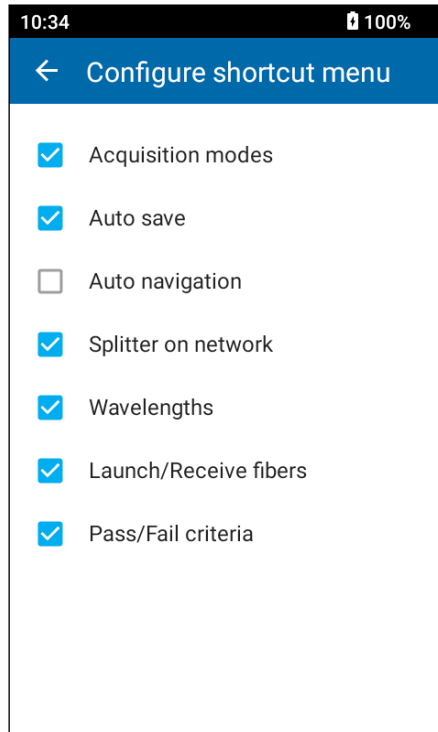

Your selection(s) will be taken into account immediately.

**To access the shortcut menu from the main window:**

Tap the arrow at the bottom of the window.

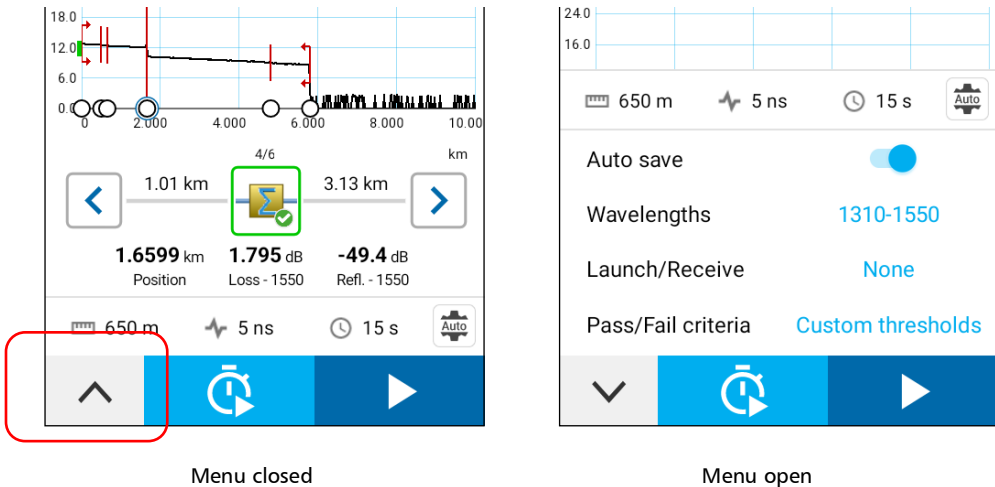

## Setting the Detection Thresholds

You can define various detection thresholds on your unit:

- *Splice loss*: Current setting for detecting small non-reflective events during trace analysis.
- *End-of-fiber*: Current setting for the loss at which the analysis is stopped. If a splitter is configured, the end of fiber will not be taken under account..
- *Macrobend delta loss value*: Your unit can locate macrobends by comparing the loss value of an event at a given wavelength with the loss value at the same location with another wavelength. The macrobend is detected if of the two loss values, the greater loss occurred at the greater wavelength and the difference between the two loss values exceeds the defined delta loss value. The default delta loss value is 0.5 dB (which is suitable for most fibers).

**To set the detection threshold values:**

1. From the main menu, tap .
2. Under **OTDR**, tap **Detection thresholds**.

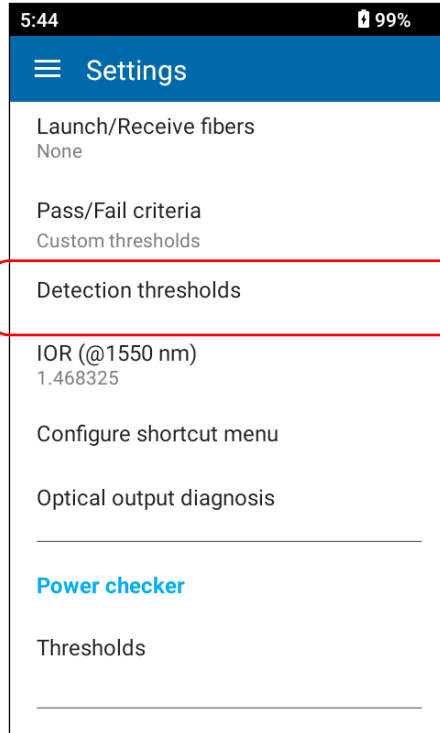

3. Set each threshold by tapping on it and modifying the values as needed.

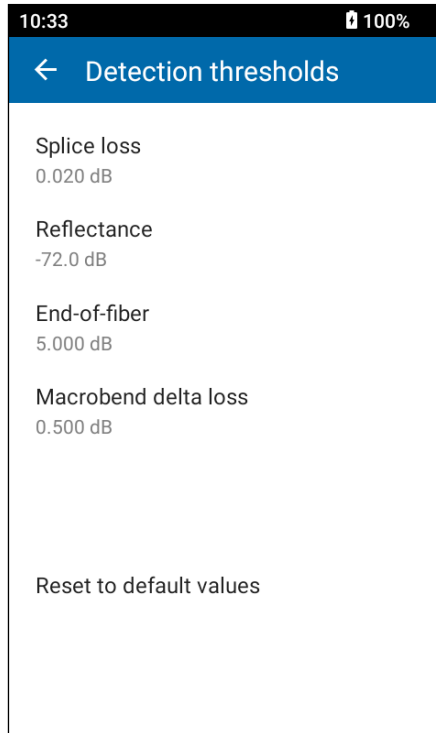

## Setting the Acquisition Parameters

The distance range, pulse width and acquisition time can be either set individually or you can have the unit set them automatically by evaluating the fiber length and setting the acquisition parameters accordingly.

- **Range:** corresponds to the distance range of the fiber under test according to the selected measurement units.

Changing the distance range modifies the available settings of the pulse width and leaves only the settings available for the specified range.

- **Pulse:** corresponds to the pulse width for the test. A longer pulse allows you to probe further along the fiber, but results in less resolution. A shorter pulse width provides higher resolution, but less distance range.

**Note:** *Not all pulse widths are compatible with all distance ranges.*

- **Duration:** corresponds to the acquisition duration (period during which results will be averaged). Generally, longer acquisition times generate cleaner traces (this is especially true with long-distance traces) because as the acquisition time increases, more of the noise is averaged out. This averaging increases the signal-to-noise ratio (SNR) and the OTDR's ability to detect small events.

The time settings will also determine how the timer (displayed in the toolbar) counts time during testing.

**To set the acquisition parameters:**

1. From the main menu, tap .
2. Under **OTDR**, tap **Acquisition parameters**.

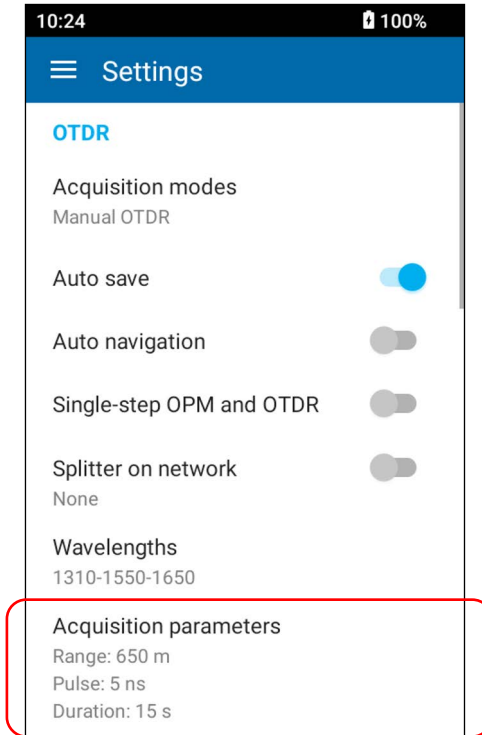

3. If you want to enable the automatic selection of the pulse and range values, use the corresponding toggle, otherwise, tap on each of the setting to select the desired value.

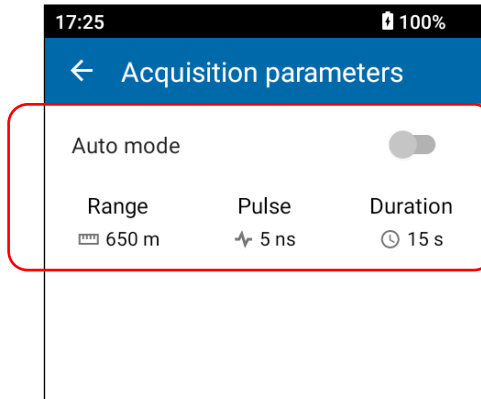

You can also select the values or enable the auto mode in the main OTDR window by tapping on them.



## Setting up Splitter Detection

When there are splitters on the network, you can enable their detection and set the ratio so that they are taken into account in your measurement.

### To enable splitter detection and select a ratio:

1. From the main menu, tap  .
2. Under **OTDR**, tap the **Splitter on network** toggle to enable splitter detection.

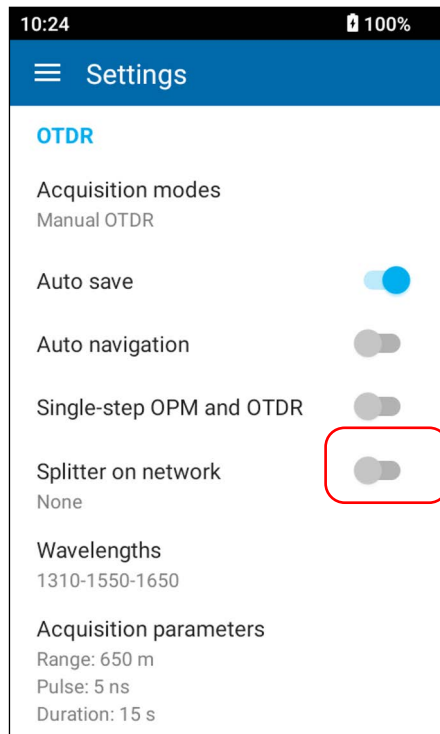

3. To set the ratio, tap **Splitter on network**.
4. Tap **+** to add the splitter, then select the corresponding ratio.

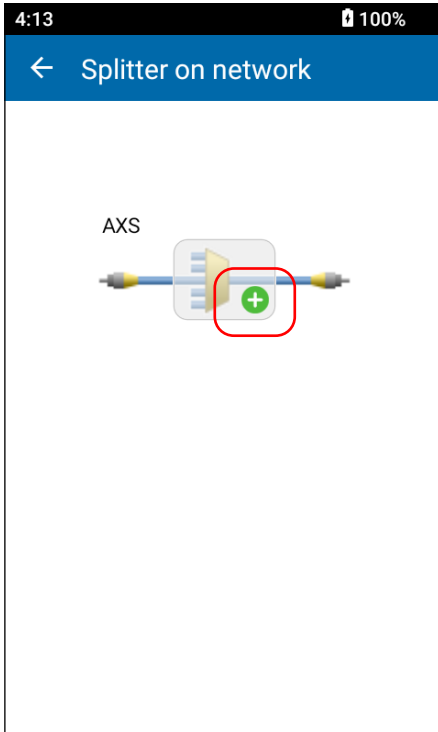

5. Select the desired ratio.

**6.** To set a second splitter, tap on the next + and repeat step 4.

**Note:** To set the second splitter, the first splitter must be set to a value other than *None*.

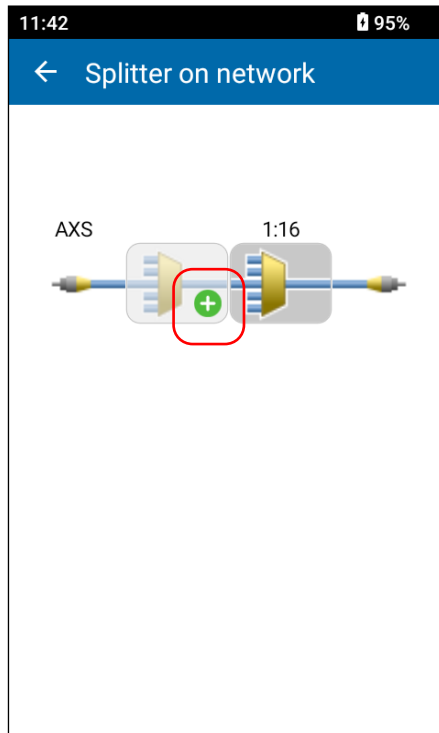

## Resetting Your Unit Settings and Data

At any time, you can use one of these options, according to your needs:

- *Reset settings* resets all settings of the unit that you have customized, such as the thresholds, as well as power checker and source settings to their default values
- *Reset AXS* resets all settings, plus erase all measurements and jobs.

**To reset the values on your unit:**

1. From the main menu, tap .
2. Scroll down to the **Device settings** section.
3. Tap **Reset options**.

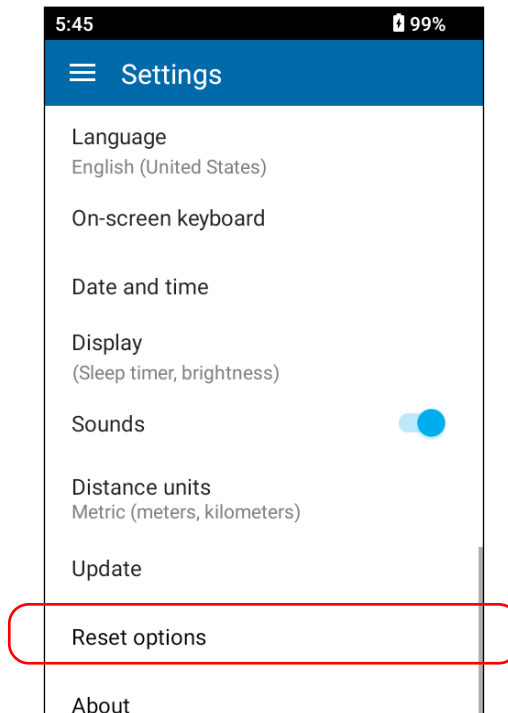

4. Select the desired option.

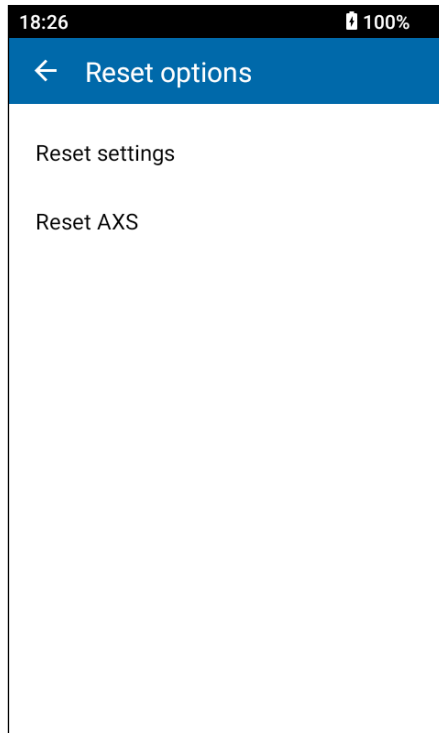

5. Tap **OK** to confirm your choice.

## Using the VFL

Your unit may be equipped with a VFL that you can set to continuous light emission or you can have the signal to blink.





### WARNING

Do not install or terminate fibers while a light source is active. Never look directly into a live fiber and ensure that your eyes are protected at all times.

#### To activate the VFL:

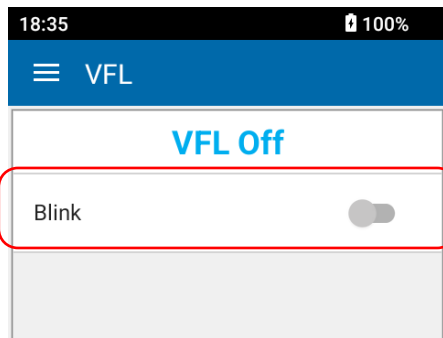
1. From the main menu, tap .
2. Tap on the toggle if you want to use the blinking mode.



3. Tap  to start the light emission.

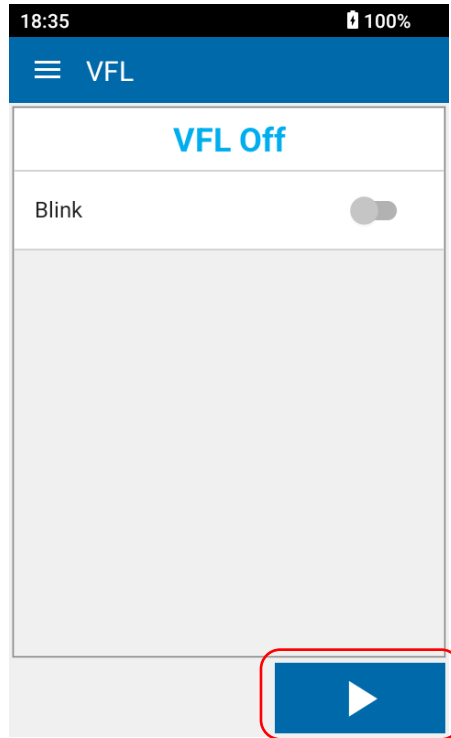

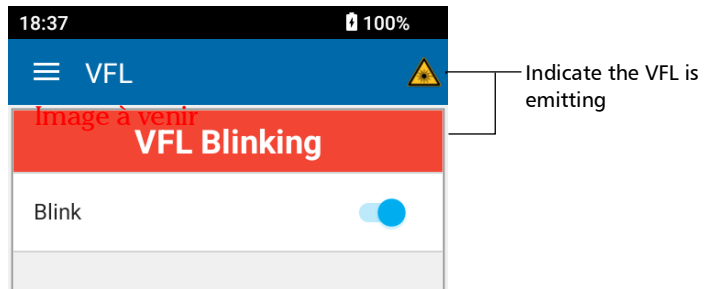

A blinking icon and a red banner clearly indicate when the VFL is on.



**Note:** The icon can also be used to access the VFL menu.

**To deactivate the VFL:**

1. From the main menu, tap .
2. Tap .

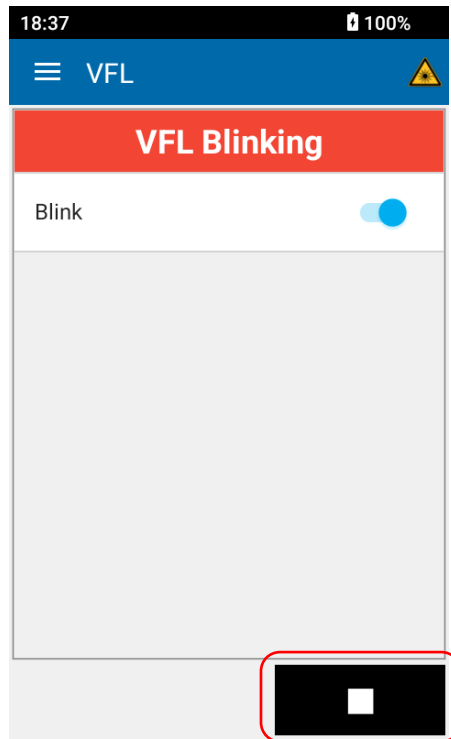

# 5 Testing Fibers

## Performing Measurements

The AXS Handheld OTDR allows you to test fibers with different measurement modes. You may want to set basic parameters before starting a measurement according to your needs:

- The wavelengths at which you want to perform the measurements (see *Selecting Test Wavelengths* on page 52 for details)
- The thresholds associated with the pass/fail criteria (see *Working With Pass/Fail Thresholds* on page 63 for details)
- The length of the launch and receive test fibers (see *Working With Launch and Receive Test Fibers* on page 60 for details)
- The IOR value (see *Configuring the IOR Value* on page 68 for details)
- The automatic saving of measurements (see *Enabling or Disabling Auto Save* on page 56)
- The automatic navigation of test points (see *Enabling or Disabling Auto Navigation* on page 57)
- The power meter thresholds (see *Setting Power Checker Thresholds* on page 54)

**To perform measurements:**

1. Clean the connectors properly.
2. Connect the launch fiber or the fiber under test to the AXS Handheld OTDR port.



## CAUTION

Ensure that the connector of the launch or receive fiber always matches the connector of the unit (APC or UPC). Joining mismatched connectors will damage the ferrules.

3. On your unit, ensure that the parameters have been set according to your needs.
4. From the main menu, tap **Active job** to access the **My Jobs** page and select a test point. For more information, see *Understanding the My Jobs Page* on page 99.

OR

Tap **OTDR** to go to the active test point from the active job.

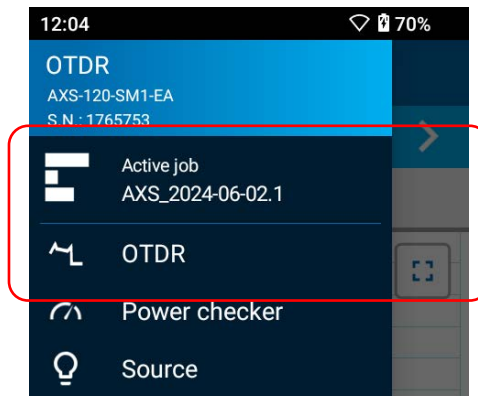

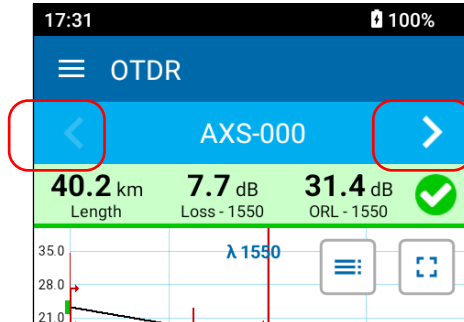

5. To change the test point, tap the navigation arrows.

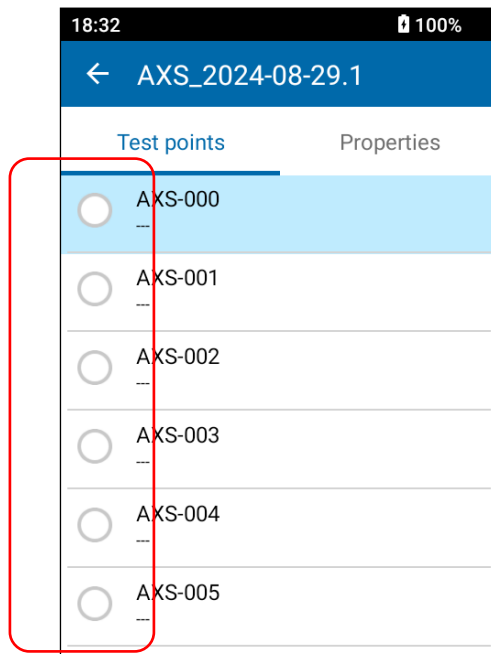

OR

Tap the test point identifier to access the list of test points associated with the active job, then tap on a test point identifier to go to the OTDR main window.



6. Tap the  button to start the measurement.

**Note:** *When a measurement is underway, the navigation arrows are disabled and you cannot browse through the measurements you have already performed.*

Once a measurement is performed, you can view the results in different parts of the screen, the results table or view the OTDR trace. See *Managing Test Results* on page 127 for details.

For information on configuring your unit's behavior when saving measurements, see *Saving Measurements* on page 140.

## Performing a Measurement Again

All measurements are performed the same way either you are using your AXS Handheld OTDR with or without a cloud-based job.

However, you can redo a measurement that has already been taken in a job.

**Note:** *When a measurement is underway, the navigation arrows are disabled and you cannot browse through the measurements you have already performed.*



### IMPORTANT

Once you redo an existing measurement, the previous result is deleted. Only the new result will be available when the measurement is complete.

#### **To perform a measurement again:**

1. Select the measurement you want to perform again.
2. Tap  to redo the measurement. You will be prompted to confirm that you want to overwrite the existing measurement.

The new result is available as soon as the measurement is complete.

## Monitoring Fibers in Real-Time Mode

The real-time mode can allow you to see sudden alterations in the fiber link. In this mode, the trace is refreshed until you stop the acquisition.

**Note:** *As this is a real-time action, there will be no resulting status or acquisition data on-screen when you stop the monitoring.*

### **To start monitoring in real-time mode:**

1. Clean the connectors properly.
2. Connect the launch fiber or the fiber under test to the AXS Handheld OTDR port.



## CAUTION

Ensure that the connector of the launch or receive fiber always matches the connector of the unit (APC or UPC). Joining mismatched connectors will damage the ferrules.

3. On your unit, ensure that the parameters have been set according to your needs.

- From the main menu, tap **Active job** to access the **My Jobs** page and select a test point. For more information, see *Understanding the My Jobs Page* on page 99.

OR

Tap **OTDR** to go to the active test point from the active job.

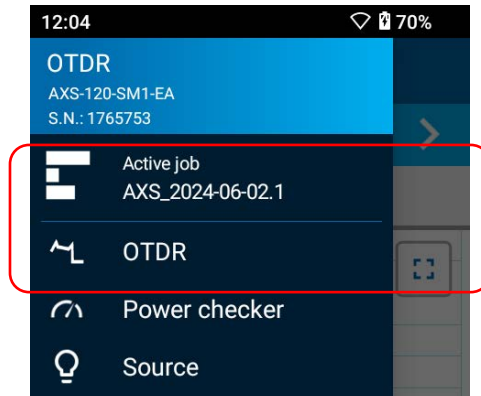

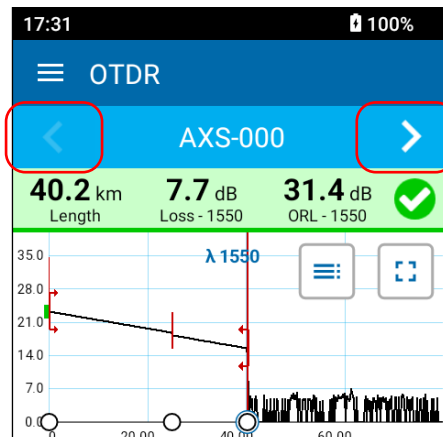

- To change the test point, tap the navigation arrows.

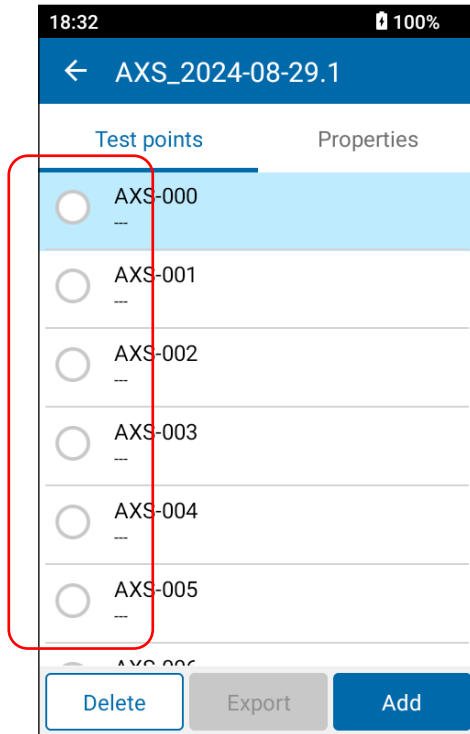

OR

Tap the test point identifier to access the list of test points associated with the active job, then tap on a test point identifier to go to the OTDR main window.



6. Tap the  button to start the measurement.



While the monitoring is running, tap  to access the trace viewer, where you can zoom in or out of the trace by pinching in or out of the screen, change the wavelength, distance and pulse values like you can in the standard view, plus move markers A and B.

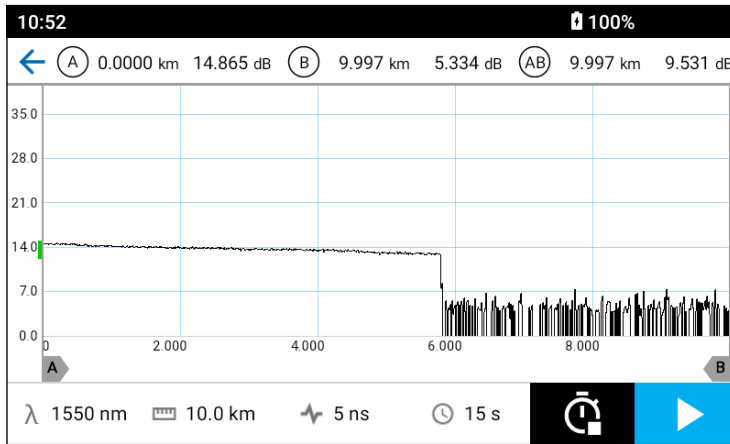

**Note:** If you tap  while the real-time monitoring is active, the unit will start a standard acquisition. This could be useful to perform an acquisition using the settings you have chosen for real-time monitoring.

7. Tap again to stop monitoring.

## Measuring Power

The Power Checker will let you measure power on the available wavelengths according to the thresholds, either individual or general, that you have set. The Power Checker will also indicate the tone for the signal.

**Note:** You can have the power measurement taken automatically with the OTDR measurement (see page 97 for more information), or take power measurements manually as needed (the job configuration must allow OPM measurements for the save button to be available).

**To view the power measurements:**

1. Connect your optical source to the input port.
2. From the main menu, tap .
3. If you have not done so already, set thresholds for your measurements as explained in *Setting Power Checker Thresholds* on page 54.
4. Tap the wavelength at the bottom of the window to select the one that matches your source.

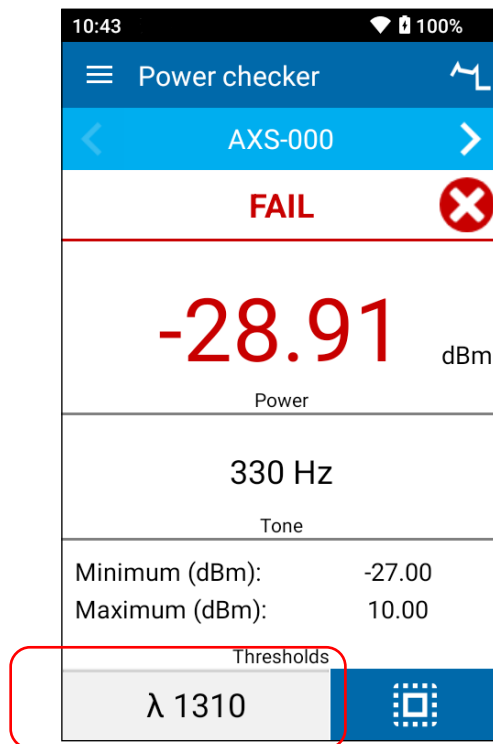

5. Start the light emission on your source to view the measurements.

6. If you want to save the power measurement, tap 

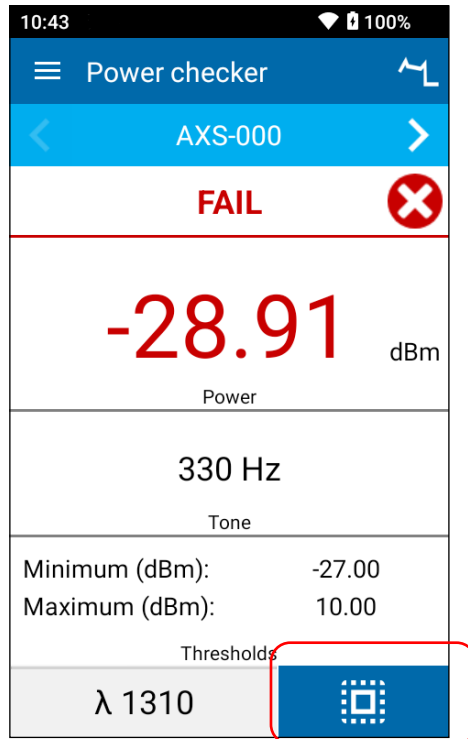

**To take power measurements automatically when performing an OTDR measurement:**

1. From the main menu, tap .
2. Scroll down to the **OTDR** section.
3. With the **Single-step OPM and OTDR** toggle, enable the automated measurement.

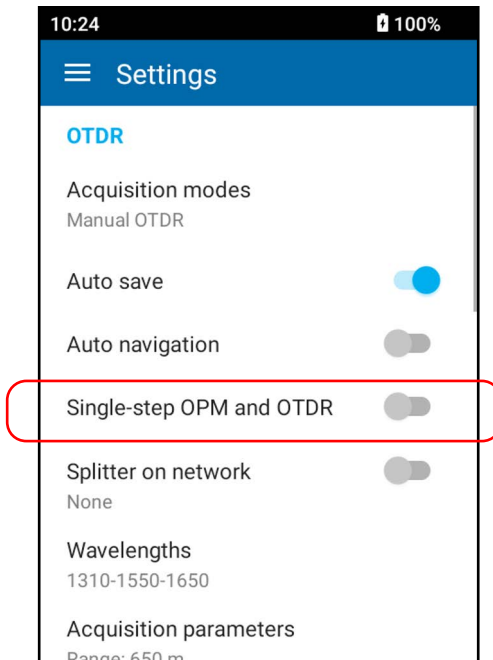

When you start the next measurement, the unit will take the power measurement, then the OTDR measurement.

# 6

## *Working With Jobs*

Every measurement you take with your unit is part of a local job or a cloud-based job for units with wireless capabilities. You can work with local jobs that you create directly on your unit or with cloud-based jobs that have already been created and assigned to you. You can change the active job, create and edit jobs directly on your unit.

When working with jobs, you can perform certain tasks such as the following:

- Select/change the active job
- Select a test configuration to use
- Create/delete jobs
- Create/delete test points
- View the synchronization status of cloud jobs
- View properties for jobs and test points
- View the job creation date
- View the total number of measurements saved
- View the pass/fail status for each test point
- View the date/time of the latest measurement, if any, for each test point

## Understanding the My Jobs Page

From the **My jobs** page, you can see the list of jobs you have created on your unit or that have been sent to your unit through the EXFO Exchange mobile application. Tasks you can perform on this page include:

- Create and delete local jobs.
- Select a new active job.
- View and work with Cloud-based jobs.
- See the current synchronization status with the Cloud for each job.
- Delete Cloud-based jobs from the unit.

**Note:** When you receive a job sent from the EXFO Exchange mobile application, it becomes the active job.

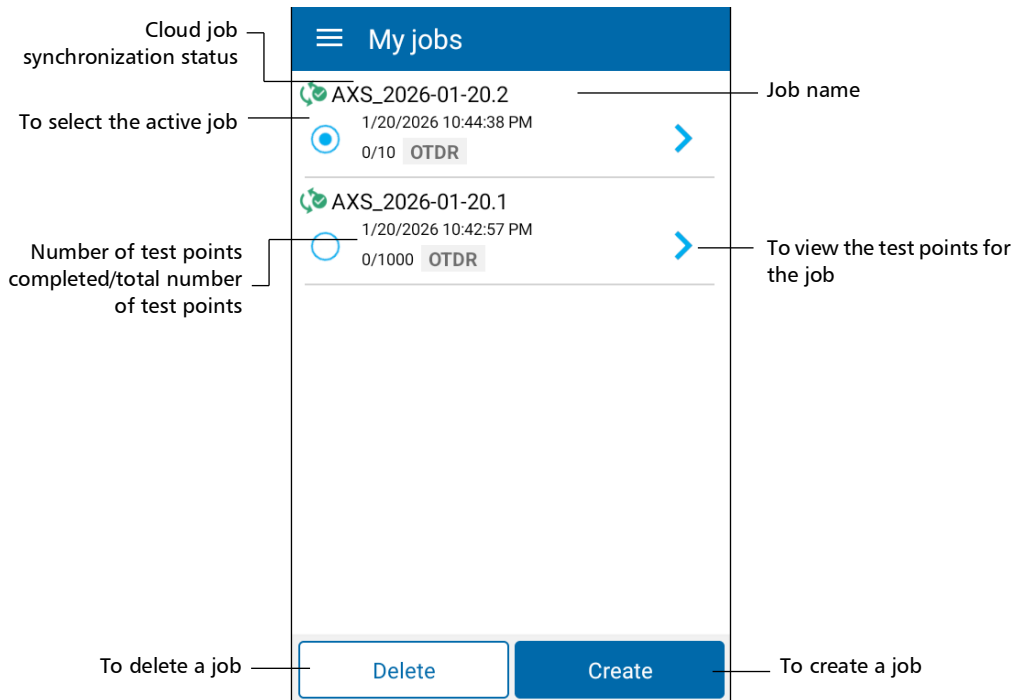

## Understanding the Test Points Page

Your unit can generate a list of test points based on the information you provide. For more information, see *Generating Valid Test Point Identifiers* on page 101.

You can also add and delete test points as needed. For more information, see *Adding Test Points to a Job* on page 113 and *Deleting Test Points From a Job* on page 116.

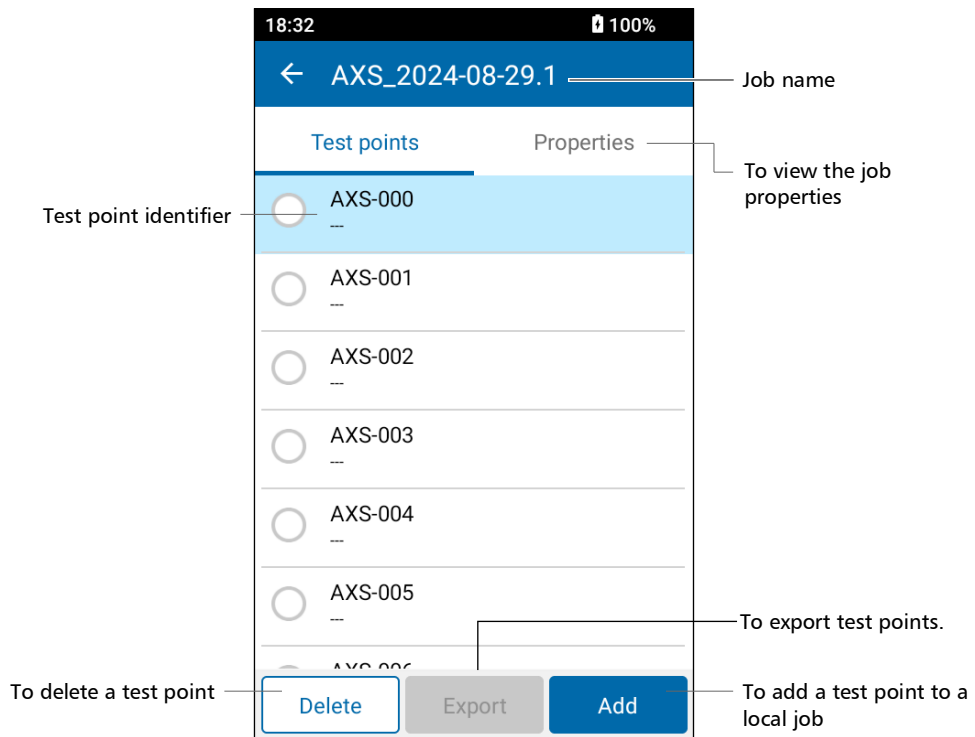

**Note:** When you select a test point from a job that is not the active job, the active job changes to the job the test point belongs to.

## Generating Valid Test Point Identifiers

All test points must be part of a job. For more information on creating a job, see *Creating Jobs* on page 106. You can create a list of test point identifiers by providing the first and last identifiers. Your unit then automatically and sequentially generates all test point identifiers between the values you provide for the first and last identifiers.

For your unit to create a valid list of sequential test point identifiers, you must provide a first and last identifier according to the rules listed in the table below.

**Note:** *If you leave the first and last identifier fields blank, your unit will create and display the default auto-naming of identifiers AXS-000 to AXS-999.*

Rule	Correct	Incorrect
The total number of test points must be less than or equal to 1000.	<ul style="list-style-type: none"> <li>➤ First identifier: AXS-000</li> <li>➤ Last identifier: AXS-999</li> </ul>	<ul style="list-style-type: none"> <li>➤ First identifier: AXS-0000</li> <li>➤ Last identifier: AXS-1200</li> </ul>
The first identifier must not be left empty. Entering only a first identifier results in the creation of one identifier only.	<ul style="list-style-type: none"> <li>➤ First identifier: AXS-000</li> <li>➤ Last identifier: AXS-999</li> <li>➤ First identifier: AXS-1</li> <li>➤ Last identifier:</li> </ul>	<ul style="list-style-type: none"> <li>➤ First identifier:</li> <li>➤ Last identifier: AXS-999</li> </ul>
The first and last identifiers must have the same number of characters	<ul style="list-style-type: none"> <li>➤ First identifier: AXS-000</li> <li>➤ Last identifier: AXS-999</li> </ul>	<ul style="list-style-type: none"> <li>➤ First identifier: AXS-00</li> <li>➤ Last identifier: AXS-999</li> </ul>
The first and last identifiers must consist of letters, numbers, or the following special characters: . @ # \$ _ & - ^ ( ) ' ; ! SPACE	<ul style="list-style-type: none"> <li>➤ First identifier: AXS&amp;000</li> <li>➤ Last identifier: AXS&amp;999</li> </ul>	<ul style="list-style-type: none"> <li>➤ First identifier: AXS%</li> <li>➤ Last identifier: AXS%</li> </ul>

<b>Rule</b>	<b>Correct</b>	<b>Incorrect</b>
For the first and last identifiers, the letters at each position must be the same or follow alphabetical order (identifiers are case-sensitive).	<ul style="list-style-type: none"> <li>➤ First identifier: AAA-000</li> <li>➤ Last identifier: AAB-010</li> </ul>	<ul style="list-style-type: none"> <li>➤ First identifier: AAB-000</li> <li>➤ Last identifier: AAA-010</li> </ul>
Special characters must match between the first and last identifiers.	<ul style="list-style-type: none"> <li>➤ First identifier: O@X&amp;000</li> <li>➤ Last identifier: O@X&amp;999</li> </ul>	<ul style="list-style-type: none"> <li>➤ First identifier: O@X&amp;000</li> <li>➤ Last identifier: O#X!999</li> </ul>
For the first and last identifiers, character types (letters, numbers, special characters) must match at each position. Letters are case-sensitive.	<ul style="list-style-type: none"> <li>➤ First identifier: A&amp;A-000</li> <li>➤ Last identifier: A&amp;B-010</li> </ul>	<ul style="list-style-type: none"> <li>➤ First identifier: A&amp;A-00A</li> <li>➤ Last identifier: &amp;AB-010</li> </ul>
Numbers in the last identifier must be equal to or greater than the numbers in the first identifier.	<ul style="list-style-type: none"> <li>➤ First identifier: AXS-000</li> <li>➤ Last identifier: AXS-119</li> </ul>	<ul style="list-style-type: none"> <li>➤ First identifier: AXS-119</li> <li>➤ Last identifier: AXS-000</li> </ul>

Your unit will display a message if you provide an invalid test point identifier with respect to the rules listed in the previous table.

**To generate valid test point identifiers for local jobs:**

1. From the main menu, tap .
2. From the **My jobs** screen, tap the blue arrow next to the job for which you want to add test points. If you want to create a new job, see *Creating Jobs* on page 106.

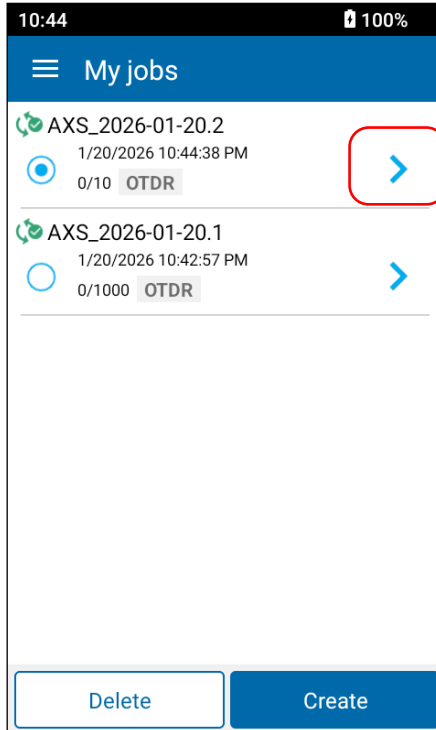

- 3.** From the list of test points displayed for the selected job, tap **Add**.

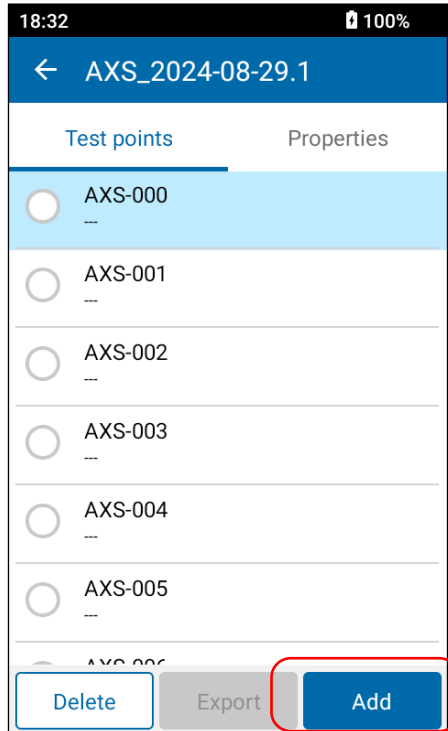

4. Enter values for the **First identifier** and the **Last identifier** (see the list of rules above for more information). If there are more than six test points, your unit displays the first three and last three identifiers in the **Preview** section along with the total number of test points generated. You can tap **Reset values** at the bottom of the screen if you wish to clear the values you entered for the first and last identifiers and return to the default auto-naming of identifiers.

10:44 100%

← Test points

OTDR  OPM

First identifier  
Test\_0

Last identifier  
Test\_9

Preview (10 test points)

Test\_0  
Test\_1  
Test\_2  
...  
Test\_7  
Test\_8  
Test\_9

Reset values Save

5. Once you are done, tap **Save**.

The new test points are added to the job.

## Creating Jobs

You can create a job and its associated test points directly from your unit. With jobs, you can perform and save a series of measurements on your unit.

The results are saved on the AXS Handheld OTDR under a list of sequential test point identifiers that you define and are generated by your unit during the local job creation process.

### To create jobs:

1. From the main menu, tap .
2. Tap **Create**.

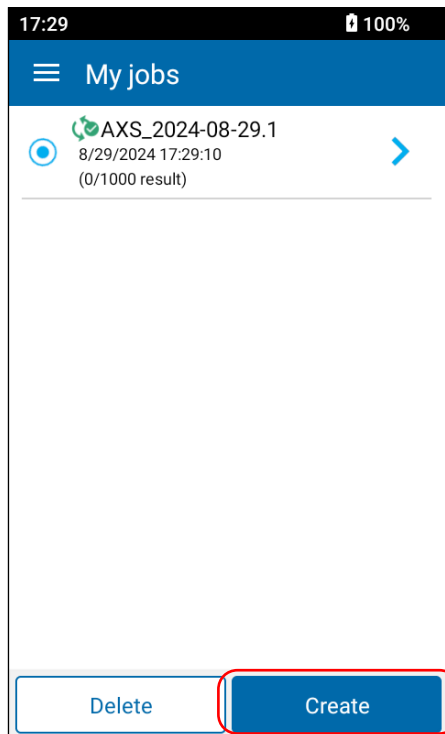

- 3.** In the **Create job** screen, you can enter a name for the new job.

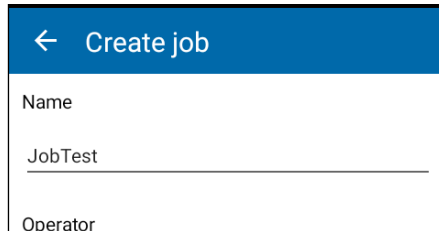

The screenshot shows a mobile application screen titled "Create job". At the top left, there is a blue header bar with a white back arrow and the text "Create job". Below the header, there is a text input field labeled "Name" containing the text "JobTest". Below the "Name" field, the label "Operator" is visible, but its corresponding input field is not yet filled.

- 4.** If you wish, you may also enter operator, company and customer names. When you have finished entering information, tap **Next**.

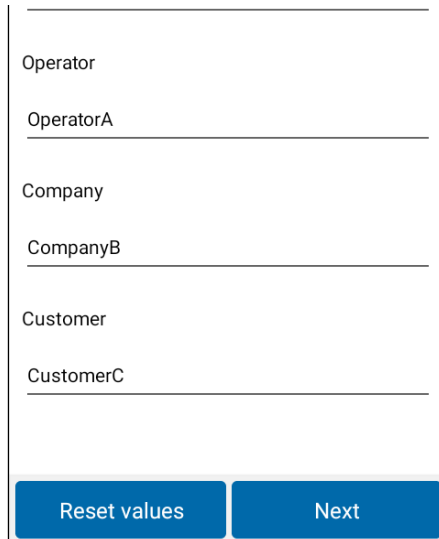

The screenshot shows the "Create job" screen with three text input fields. The first field is labeled "Operator" and contains "OperatorA". The second field is labeled "Company" and contains "CompanyB". The third field is labeled "Customer" and contains "CustomerC". At the bottom of the screen, there are two blue buttons: "Reset values" on the left and "Next" on the right.

5. In the **Test points** screen, select whether each test point will include an OTDR, an OPM measurement, or both.

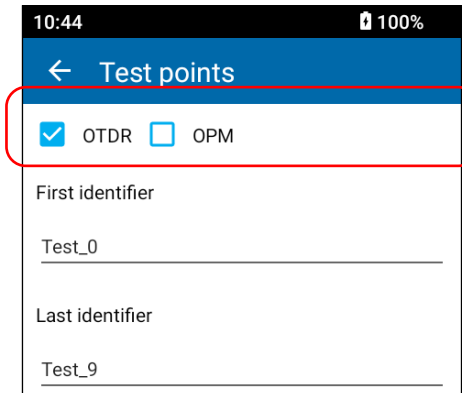

The screenshot shows a mobile application interface for 'Test points'. At the top, the status bar displays '10:44' and '100%' battery. Below the status bar is a blue header with a back arrow and the text 'Test points'. A red box highlights the selection area containing a checked checkbox for 'OTDR' and an unchecked checkbox for 'OPM'. Below this are two text input fields: 'First identifier' with the value 'Test\_0' and 'Last identifier' with the value 'Test\_9'.

6. Enter values for the **First identifier** and the **Last identifier**. Tap **Reset values** if you wish to clear the values you entered for both the first and last identifiers. For more information on generating valid test point identifiers, see *Generating Valid Test Point Identifiers* on page 101.

**Note:** If you enter a value for the **First identifier** only, your unit generates a list of one test point with the value you provide.

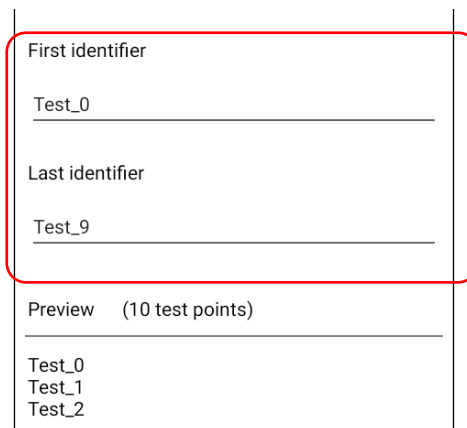

The screenshot shows the 'Test points' screen with a red box highlighting the input fields. The 'First identifier' field contains 'Test\_0' and the 'Last identifier' field contains 'Test\_9'. Below these fields is a 'Preview (10 test points)' section showing a list of test points: 'Test\_0', 'Test\_1', and 'Test\_2'.

7. When you have finished, tap **Save**.

10:44 100%

← Test points

OTDR  OPM

First identifier  
Test\_0

Last identifier  
Test\_9

Preview (10 test points)

Test\_0  
Test\_1  
Test\_2  
...  
Test\_7  
Test\_8  
Test\_9

Reset values Save

- The new job you create becomes the active job in the **My jobs** page and it is placed at the top of the list as jobs are ordered from newest to oldest. Tap the blue arrow to see the list of test points that your unit generated in the previous step.

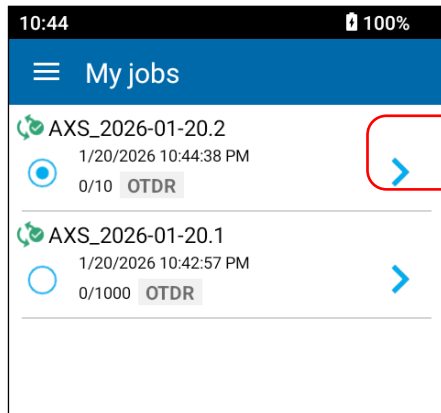

- Tap a test point to go directly to the OTDR main window.

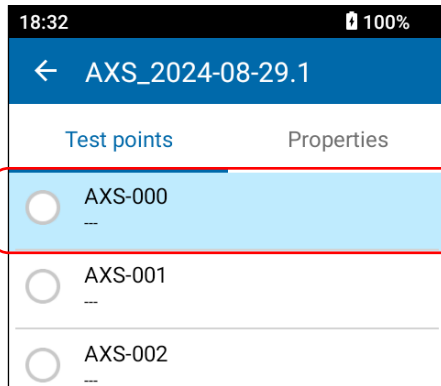

**Note:** If your unit has wireless capabilities, you can also view measurements in the EXFO Exchange mobile application. For more information, see *Synchronizing Job Results With the Smart Device and the Cloud Server* on page 156.

## Deleting Jobs

You can delete jobs you no longer need or to free up memory space. As your unit's memory approaches full capacity, messages will prompt you to delete jobs so that you can continue working with your unit.

**Note:** *You cannot delete an active job. If the job you wish to delete is the active one, you must first select another job to make it active.*

### To delete a job:

1. From the main menu, tap .
2. From the list of jobs in the **My jobs** page, tap **Delete** to access the job list for deletion.

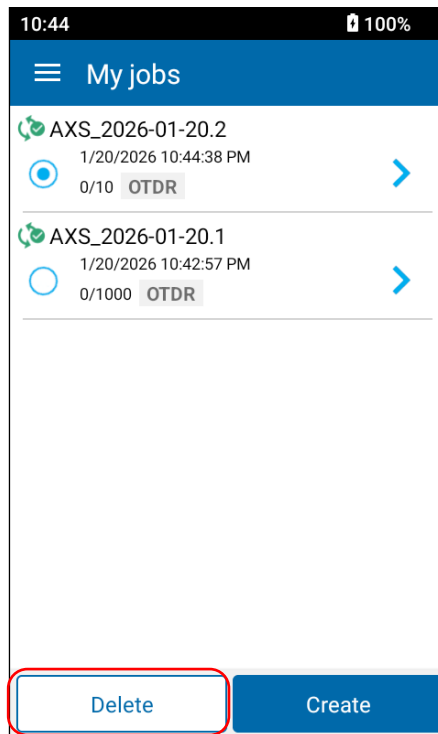

3. You can only delete non-active jobs. Select the job(s) you want to delete by selecting the corresponding check box. If you prefer to select all jobs at once, tap **Select all**.

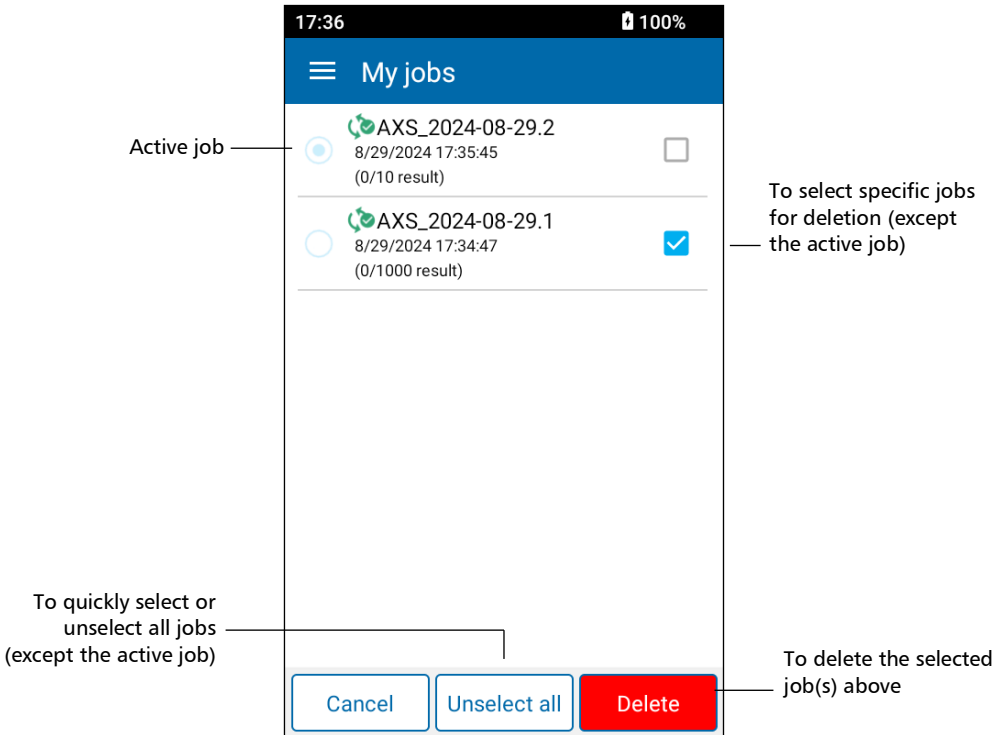

4. Tap **Delete**, then confirm your choice.

The selected jobs are deleted from the list.

## Adding Test Points to a Job

You can manually add test points to a job on your unit.

**Note:** You cannot add test points to a cloud-based job from your unit.

### To manually add test points to a local job:

1. From the main menu, tap .
2. From the **My jobs** page, tap the blue arrow next to the job to display its current list of test points.

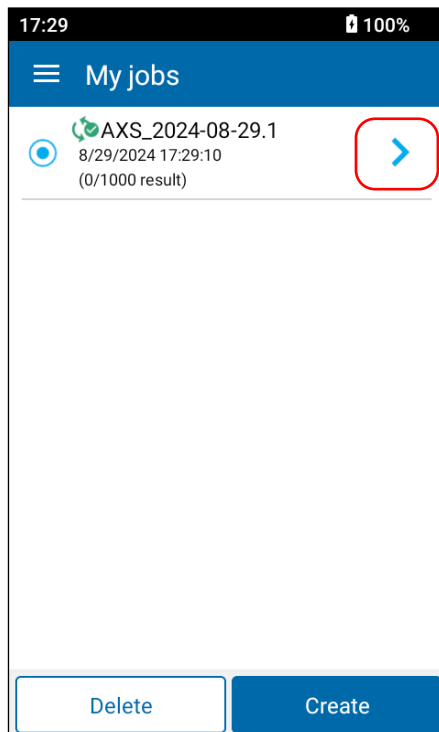

3. From the list of test points, tap **Add**.

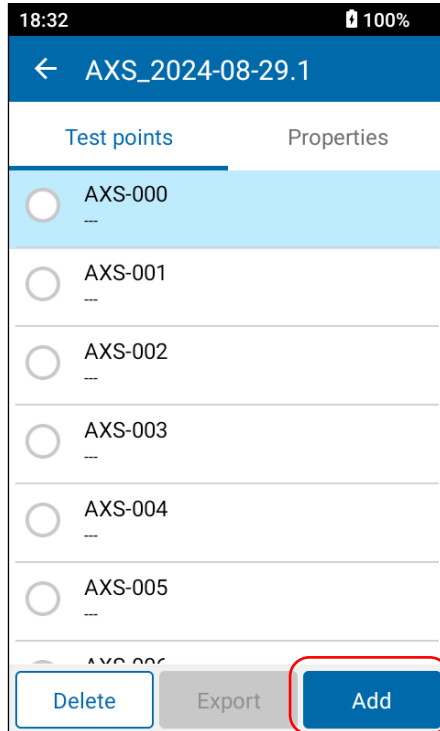

4. Enter values for the **First identifier** and the **Last identifier**. For more information on generating valid test point identifiers, see *Generating Valid Test Point Identifiers* on page 101.

← Test points

OTDR  OPM

First identifier  
Test\_0

Last identifier  
Test\_9

Preview (10 test points)

Test\_0  
Test\_1  
Test\_2  
...  
Test\_7  
Test\_8  
Test\_9

Reset values Save

5. Tap **Save**.

The new test points are added to the existing list in numerical and alphabetical order.

## Deleting Test Points From a Job

You can manually delete test points that are part of a job.

**Note:** You cannot delete test points that are part of a cloud-based job from your unit.

### To manually delete test points from a local job:

1. From the main menu, tap .
2. From the **My jobs** page, tap the blue arrow next to the job to display its list of test points.

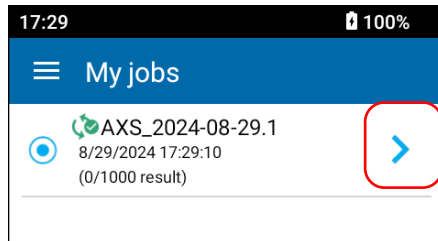

3. Tap **Delete** to access the list of test points for deletion.

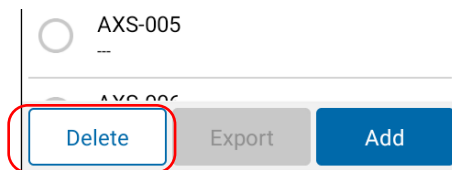

4. Select the test point(s) you want to delete by selecting the corresponding check box. If you prefer to select all test points at once, tap **Select all**.

**Note:** You cannot delete an active test point.

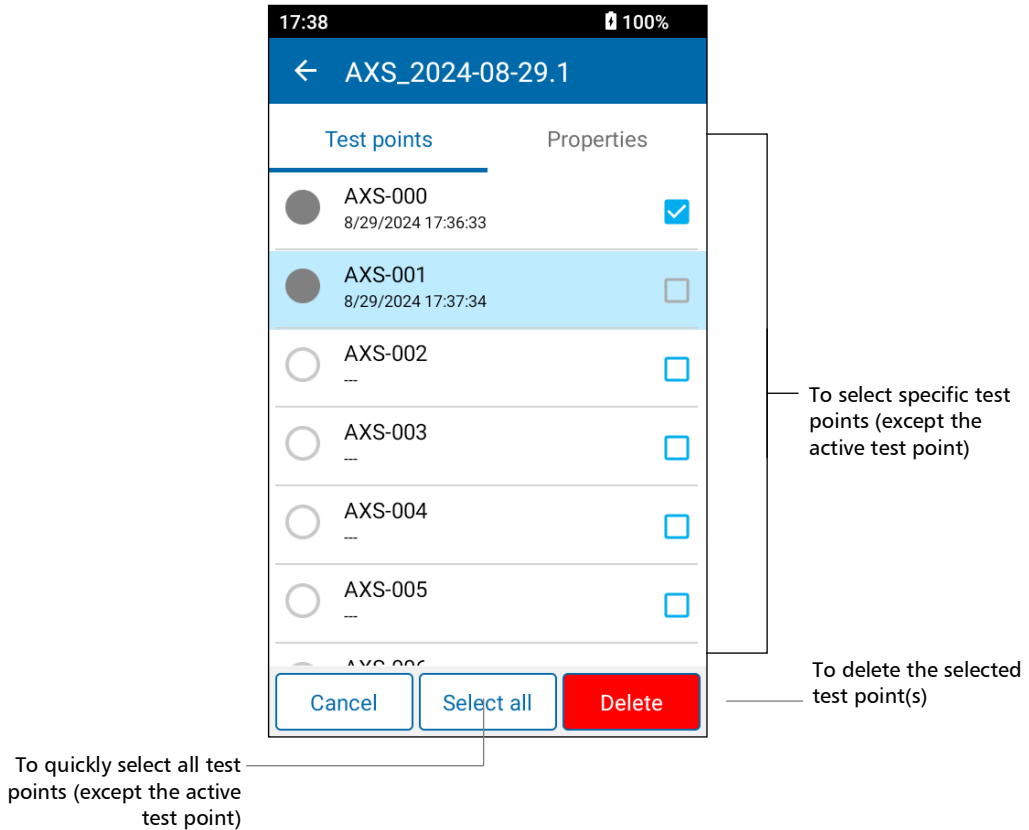

5. Tap **Delete**, then confirm your choice.

## Working With Test Configurations

Your supervisor might have created specific test configurations in the EXFO Exchange mobile application that you can use to perform your tests with the settings relevant to your job already selected for you.

Test configurations are linked to the jobs they are set for. You can have more than one configuration per job; when this is the case, your unit will select the first configuration in the list by default, but you can go select another one as needed.

**Note:** *The test configuration will apply to the next measurement you take.*

**Note:** *If there is an error in the test configuration, it will not available in the list.*

### To select a test configuration:

1. From the **OTDR** window, tap the blue ribbon at the bottom of the window to access the configurations.

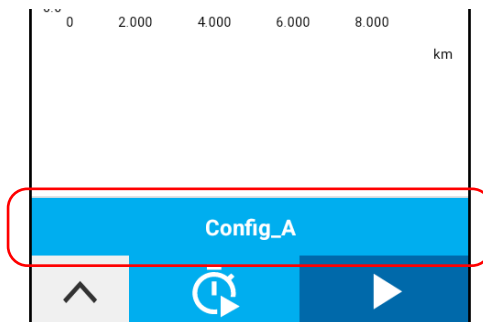

2. Select which configuration you will use for your measurements.

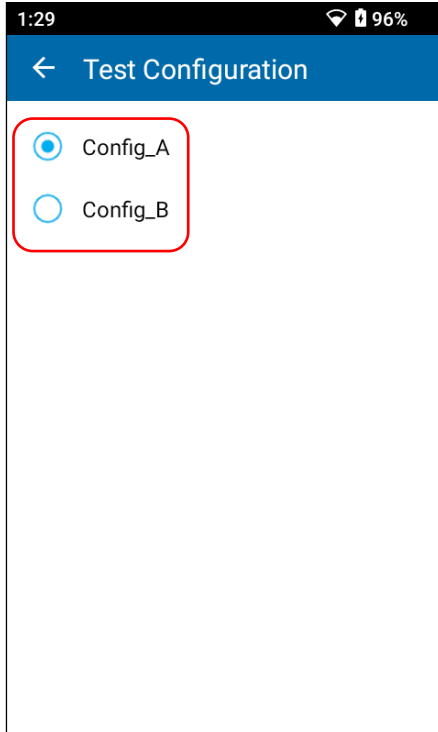

# 7

## Using the Light Source

You can use the AXS Handheld OTDR as a light source to perform measurements with a power meter. By default, the modulation is set to CW (continuous), but you can select another value, depending on the type of tests you want to perform.

- For loss measurement, you should choose a continuous pattern.
- For fiber identification, you should choose any modulation value other than continuous. This will allow the person at the other end of the link to identify the fiber under test, which is particularly useful when working with cables containing many fibers.

When the light source is on (off by default), it emits light constantly until you turn it off, but you can set a timer allowing light emission only for a certain period of time (up to 999 minutes). The first time you work with the source, the timer is disabled. The default value is set to 30 minutes when it is enabled. As soon as the timer reaches zero, the light emission stops automatically. If you enable this feature and decide not to edit the number of minutes during which you want the source to emit light, it will stop after 30 minutes. The application displays clearly the countdown on screen. The state of the timer (on or off) and the value you have entered are kept in memory when you close the page.



### IMPORTANT

- When you exit the source page, the light source stops automatically.
- If you have not set a timer to automatically turn off the source, do not forget to turn it off when the test is complete. Otherwise, the source will emit constantly and could drain the battery of the unit.

**To use the light source:**

1. From the main menu, tap .
2. Select a wavelength by tapping on it and changing the value as needed.

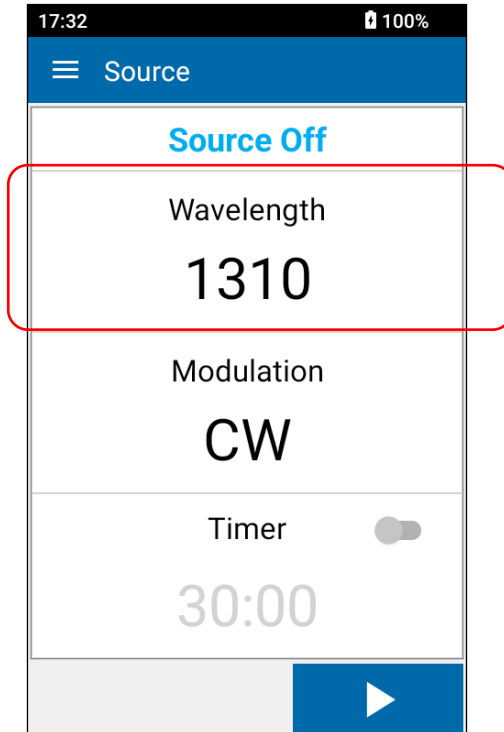

3. Select a modulation by tapping on it and selecting one type from the available choices.

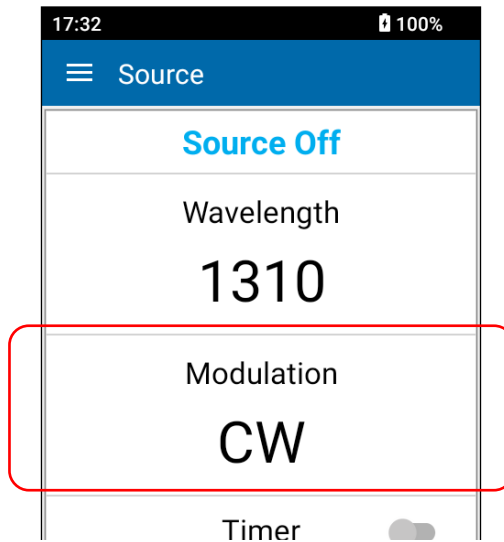

### IMPORTANT

The AXS Handheld OTDR can be used in continuous source mode (CW) to perform optical power measurements and it is compatible only with the following: high power Germanium (GeX) versions of the 300 and 600 Series, the PX1-H and PX1-PRO-H, as well as any unit's built-in GeX power meter.

The EPM-50 power meter and MPC-100 power checker are not compatible for measurements using an AXS Handheld OTDR in continuous setting.

4. To set the timer, proceed as follows:
  - 4a. If necessary, activate the feature with the toggle button.

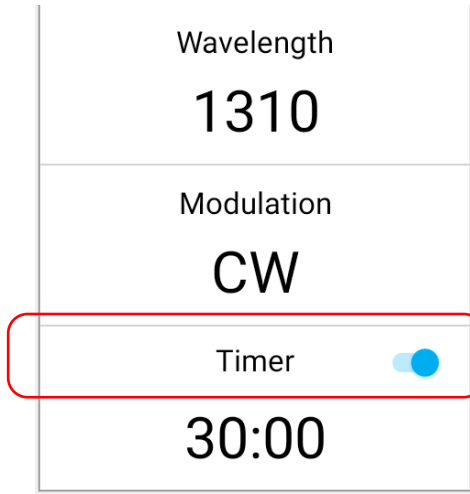

**Note:** *If you do not want to set the timer, deactivate the feature with the toggle button.*

**4b.** Tap the displayed numbers.

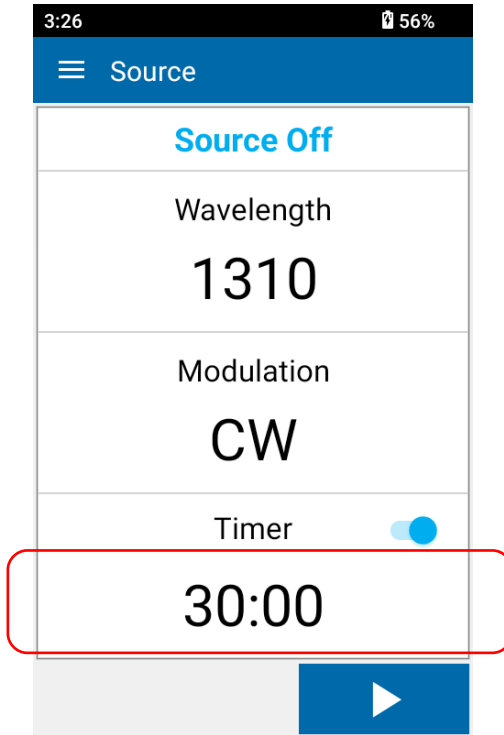

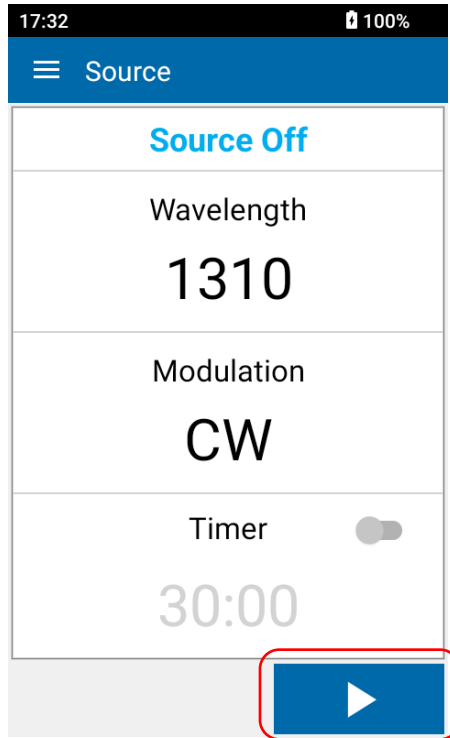

**4c.** Enter the number of minutes during which you want the source to emit light.

5. Tap  to start the light emission.

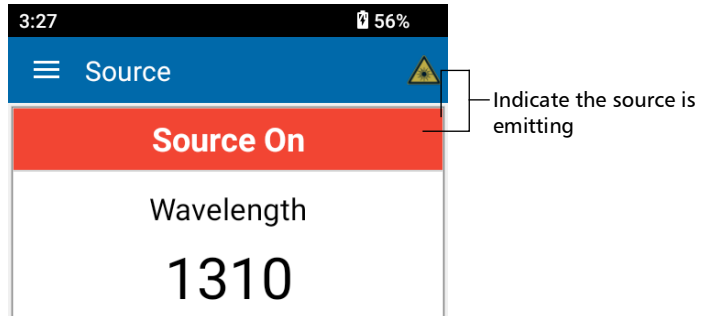

A blinking icon and a red banner clearly indicate when the light source is emitting.



6. To avoid draining the battery of the unit, tap  to stop the light emission as soon as your tests are complete.

**Note:** *If you have set the timer, the light emission stops when the value you have entered reaches zero.*

# 8

## Managing Test Results

You can view and delete measurements directly from your unit. You can also redo a measurement if needed. You can also manually delete measurements that are not part of a cloud-based job by selecting all measurements or some of them only. You cannot delete measurements that are part of a cloud-based job but you can perform a measurement that has already been done again. See *Performing Measurements* on page 86 for details.

### Viewing Measurements

The measurements you perform on your unit are saved under a test point that you create in a local job or in a job that someone has created for you with the EXFO Exchange mobile application for units with wireless capabilities.

#### **To view measurements from the OTDR main window:**

1. From the main menu, tap .
2. From the OTDR main window, use the arrows to view the available measurements, in turn.

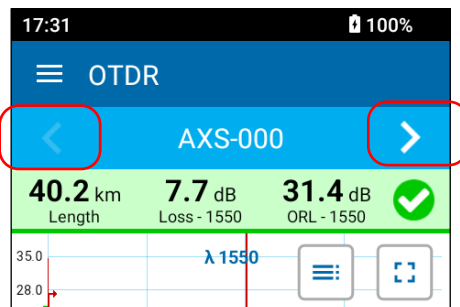

OR

Tap the test point identifier to access the list of points for your job.

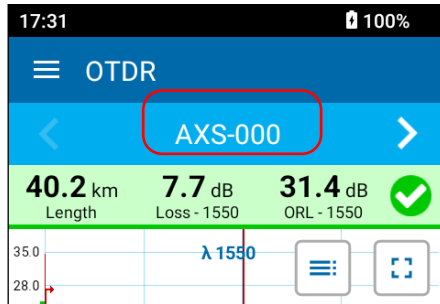

**To view measurements from the list of test point identifiers:**

1. From the main menu, tap .
2. From the main page, tap the blue arrow to display the list of test points in a job.

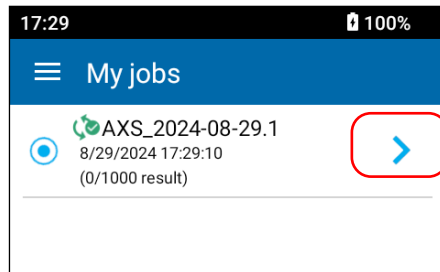

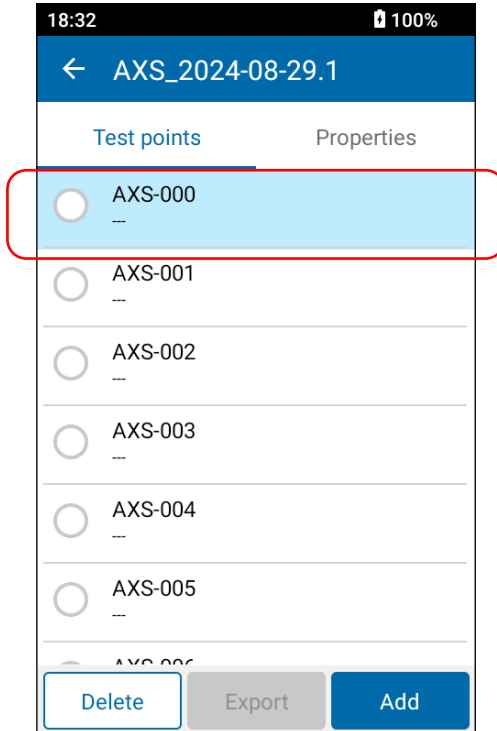

- From the list of test points, tap a test point to see the corresponding measurement in the OTDR main window.



## Working With Link Summary

You can view, at a glance, the pass/fail status of the link, the link length, the loss and ORL values for the link. The pass/fail status depends on the status of each value and it will be:

-  : when each element on the link and the link itself have a pass status
-  : when at least one of the element on the link or the link itself has a fail status
-  : when no threshold is configured or a span value (length, loss, ORL) is not available. It could also be because the status of an element is unknown.

The application displays a pass/fail status when thresholds are applied.

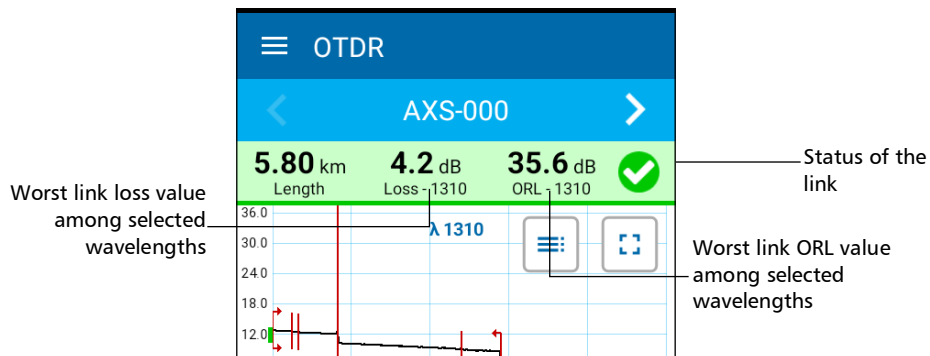

**Note:** If the link ORL value is displayed with a > symbol, the value is exceeding the saturation level of the detector.







**Note:** If the reflectance value is displayed with a > symbol, the value is exceeding the saturation level of the detector.

## Working With the Optical Link Map

This graphic representation displays all of the elements on the fiber under test, one at a time.

During an acquisition, the application tags the elements it finds with icons that represent their type. It also assigns a sequential number to each element displayed along the link between the link start (A) and the link end (B). Only one identification number is assigned for a group of elements.

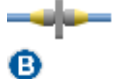
The elements are represented by the following icons:

Element Name	Element Icon	Meaning
Link start		This is the first element of the fiber link.
Splice		The splice can indicate the junction of two fiber sections, or any non-reflective loss induced by a bend or coupler, for instance.
Connector		The connector is used to join two fibers.
Connector A		Connector A corresponds to the link start.
Connector B		Connector B corresponds to the link end.
Macrobends		Macrobends can be displayed in the optical link map when more than one wavelength is present in the measurement.

## Managing Test Results

### Working With the Optical Link Map

Element Name	Element Icon	Meaning
Out of range		This element is displayed when the application cannot detect the end of fiber because of insufficient dynamic range.
Group		Several link elements are combined when they cannot be independently identified.
Link end		This is the last element of the fiber link.
Splitter		The splitter is a passive fiber optic coupler that divides light from a single fiber into two or more fiber channels. The splitter ratio is displayed beside the icon.

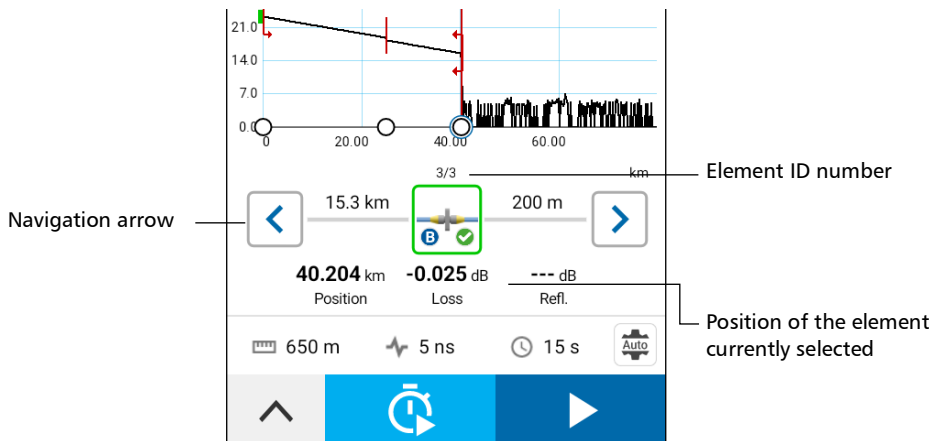

The application can detect several link elements or faults that are too close to one another to be independently identified. When this is the case, the application will display the link elements as groups and provide as much information as possible for each individual sub-element. The application will also apply a pass/fail status to each sub-element whenever possible, and a global status for the group.

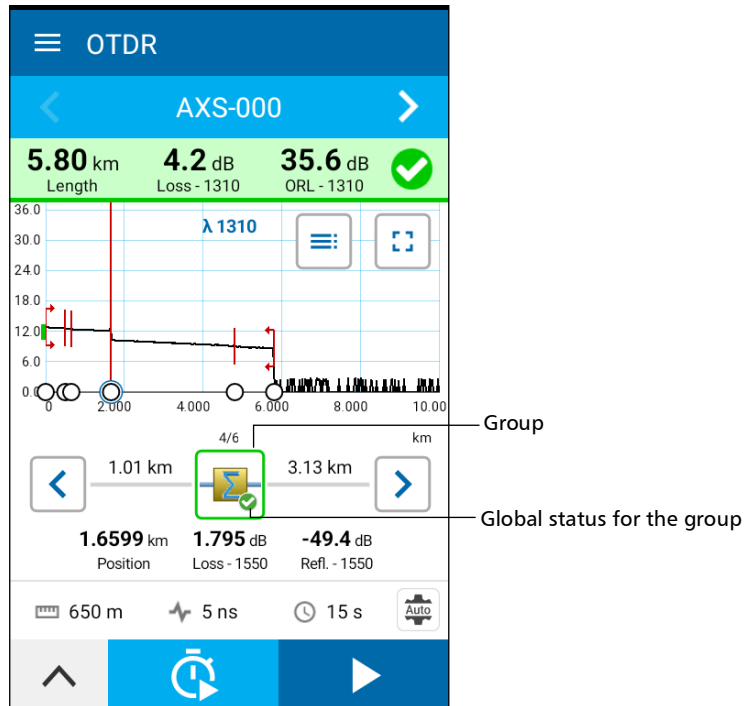

## Working With the Result Table

You can view the results in table format at the touch of a button.

### To access the element table:

Tap the corresponding icon in the main window.

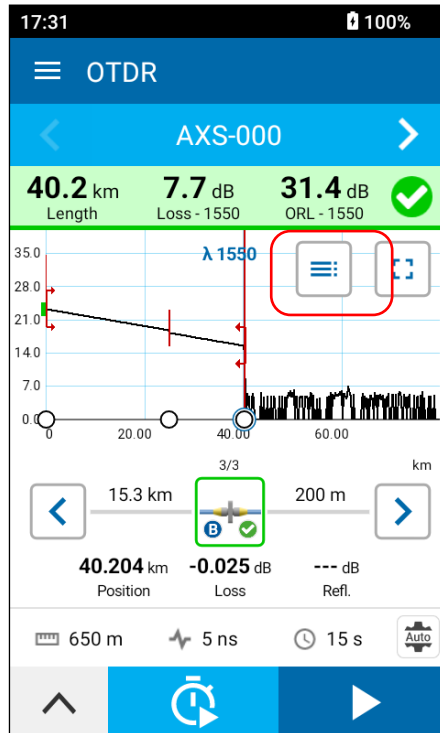

You can switch between the tabs displaying the elements or the sections by tapping on the corresponding tab. Tap on an element to open its detailed window.

Results table				
Elements			Sections	
No.	Pos. (km)	Loss (dB)	Refl. (dB)	Cumul. (dB)
1	0.0000	—	—	0.000
2	0.5012	0.084	>70.7	0.278
3	0.6511	0.087	>71.0	0.447
4	1.0895	0.061	—	0.764
5	1.1011	-0.025	—	0.732
6	1.1153	-0.004	>72.0	0.728

Selected wavelength: 1310 1550

## Changing an Element Type

You can change the element type identified as “splice” to the element type “connector”. The splice must be between the link start and the link end. A “\*” sign appears to notify you that the former splice is now considered as a connector. Once the element type has been changed, the unit reanalyzes the measurement automatically by reapplying the thresholds of the connector. Both the pass/fail status of the element as well as the status of the whole link are refreshed.

**Note:** You can change back the element type now identified as “connector” to the element type “splice” but the “\*” sign will still be displayed.





### IMPORTANT

No confirmation message will be displayed to confirm your change.

#### To change an element type:

1. In the optical link map area, tap the element you want to modify.  
See *Working With Link Summary* on page 130 for details.
2. Use the blue arrows  to change the element type.

← Element details	
←	2.60 km 2/3 1.40 km →
* 	Splice  2.6007 km 
Loss	
1550	0.700 dB
Reflectance	

## Viewing Diagnoses on Elements

Your AXS Handheld OTDR can provide a diagnosis to explain the issues you may find when inspecting a link and point toward possible solutions.

If a diagnosis is available for an element, it will display a small *i* on the upper right corner. Access the element details to view the corresponding details.

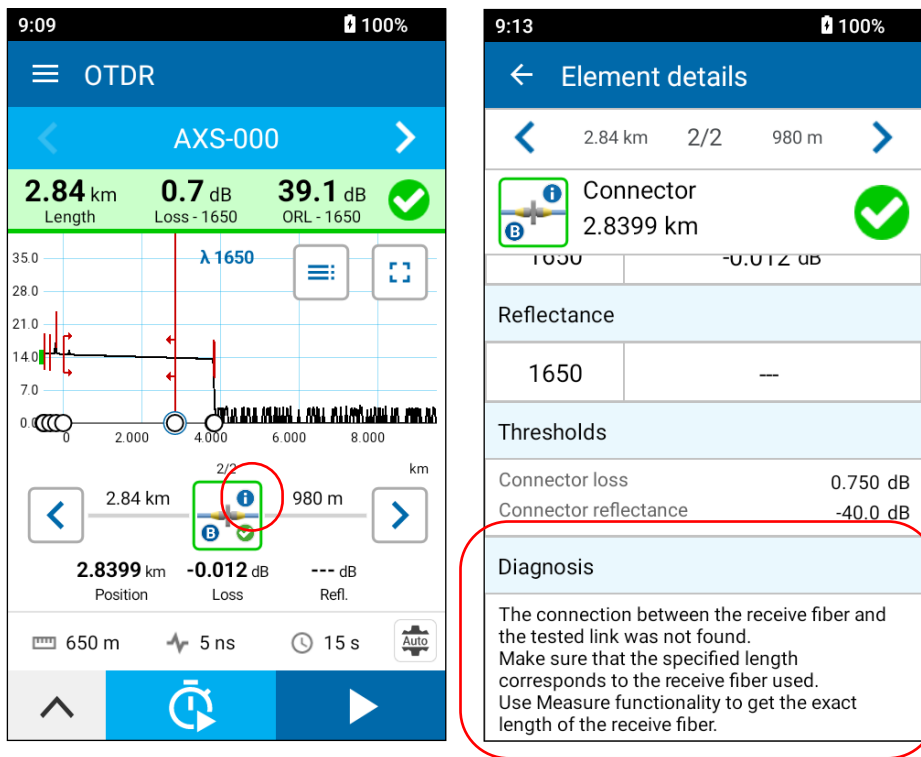

## Working with the OTDR Trace Viewer

The OTDR trace viewer allows you to use markers on your measurements or zoom in on elements.

### To access the trace viewer:

Tap the corresponding button in the main window.

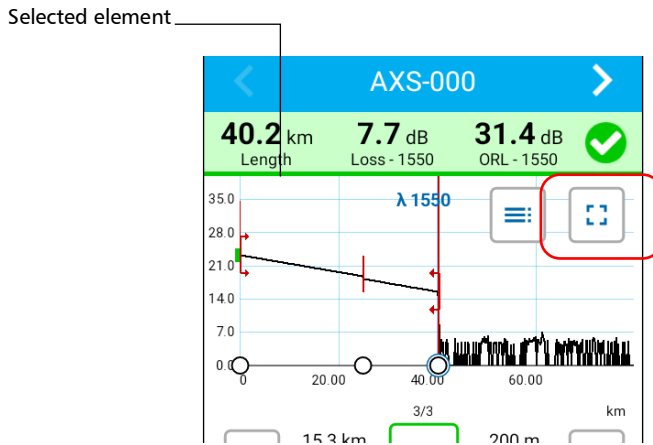

The viewer appears with the focus on the selected element.

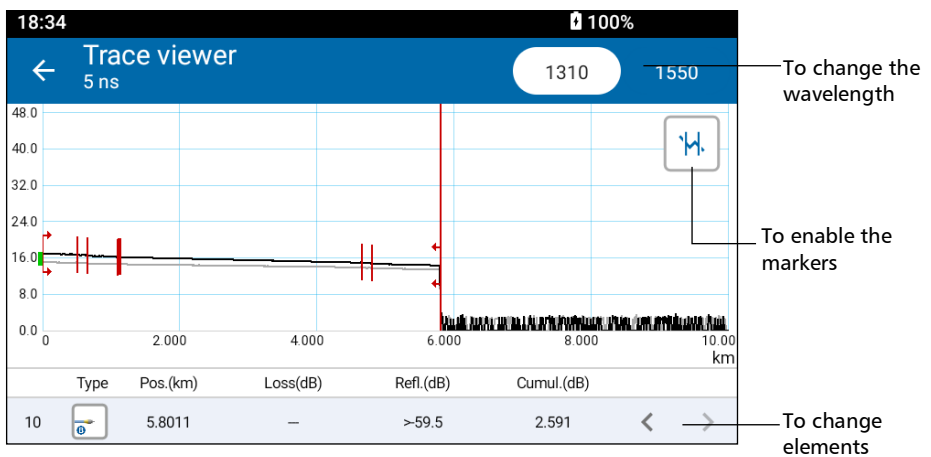

**To use the markers:**

1. From the trace viewer, access the markers controls.

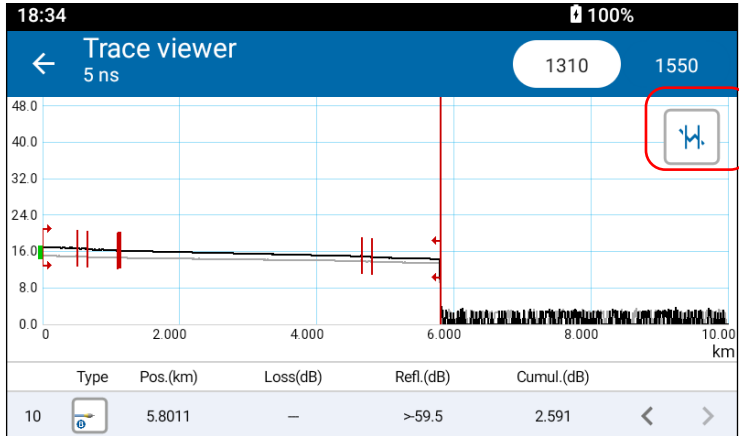

2. Tap and drag markers A and B according to your needs. The corresponding information is updated at the bottom of the window.

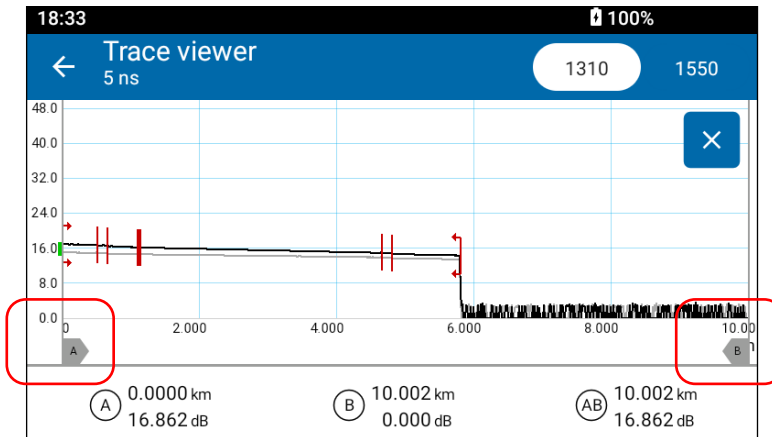

## Saving Measurements



You can use your unit to perform quick measurements without saving every result or you can define your unit's behavior once the measurement process is complete. You can enable the automatic saving of each measurement taken or you can save only the measurements you wish to keep by using the quick save feature.

**Note:** *You can also have the unit go to the next available test point after a measurement is saved. For more information on enabling or disabling the auto navigation to the next test point, see [Enabling or Disabling Auto Navigation](#) on page 57.*

### **To save measurements automatically:**

Enable the feature as explained in [Enabling or Disabling Auto Save](#) on page 56.

### **To save measurement manually:**

1. Select the desired test point to perform a measurement. For more information on selecting test points, see [Performing Measurements](#) on page 86.
2. Tap the  button to perform the measurement.
3. The quick save icon at the top of the window changes from  to  indicating that the current measurement is not saved. Once you are happy with your measurement, tap on the icon to save it.

When you attempt to navigate to the previous or next test point, you will receive a warning message that the current measurement will be lost. Tap the quick save icon to save the current measurement.

4. Tap the  button to navigate to the next test point.

Your unit is ready for a new measurement.

## Exporting Measurements

You can export your job results to view them in a post-processing application or as a PDF report.

**Note:** *This feature is not available if you have not performed any measurements on a job.*

### To export measurements:

1. Connect a storage device to the USB port of your unit.
2. From the main menu, tap .
3. From the **My jobs** page, tap the blue arrow next to the job to display its list of test points.

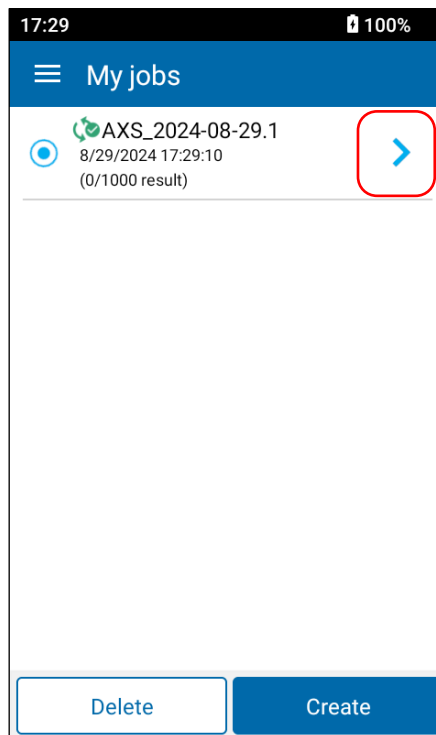

4. Tap **Export** to access the list of test points.
5. Select the test point(s) you want to export by selecting the corresponding check box. If you prefer to select all test points at once, tap **Select all**.

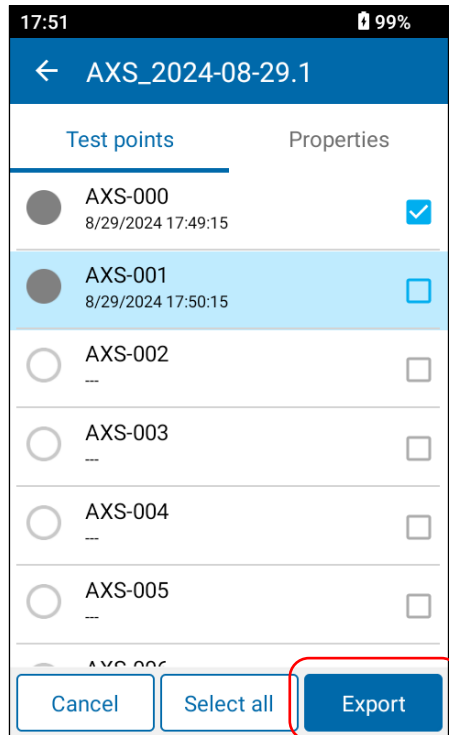

6. Tap **Export**, then select the formats you need.

**Note:** *If you have test results from the power checker, the native format will also indicate .opm.*

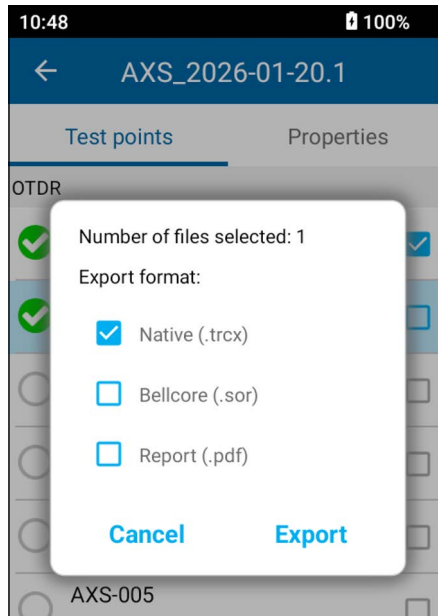

7. Tap **Export** to confirm your choice. The results are sent to the storage device.

# 9

## Working With the EXFO Exchange mobile application

You can use your AXS Handheld OTDR in association with a smart device equipped with the EXFO Exchange mobile application allowing you to document your results, archive them on a cloud server, send jobs to your units and generate reports.

- Note:** *If your unit does not have wireless capabilities, you cannot work with the EXFO Exchange mobile application.*
- Note:** *In addition to all the other features explained throughout this documentation, you also have access to the features presented hereafter if you work with cloud-based jobs.*
- Note:** *The EXFO Exchange mobile application gives you access to certain features even if you do not log on to your EXFO Exchange mobile application account. However, to benefit from all the available features, you will need to log in. The procedures presented throughout this user documentation will indicate if a logon is required.*
- Note:** *Depending on the type of smart device you are using, the appearance of the EXFO Exchange mobile application may vary slightly from the illustrations presented in this documentation. Unless otherwise specified, the information applies both to the Android- and iOS-based smart devices.*
- Note:** *The measurement units used on your AXS Handheld OTDR are independent from those used with EXFO Exchange mobile application jobs. This means that you may have to make changes to ensure consistency in the selected measurement units.*

## **Installing the Exchange Mobile Application on Your Smart Device**

Before you start working, if you intend to work with cloud-based jobs and archive information on the cloud, you will need to install the EXFO Exchange mobile application on your smart device.

***To install the EXFO Exchange mobile application:***

- 1.** Ensure that you have access to an Internet connection.
- 2.** From your Android-based smart device, open the Google Play Store (usually **Play Store** or **Play** icon).

OR

From your iOS-based smart device, open the App Store (usually **App Store** icon).



- 3.** From the Play Store or the App Store, search for *EXFO* to localize the EXFO Exchange mobile application.
- 4.** Start the installation and follow the on-screen instructions.

## **Enabling or Disabling a Connection With a Smart Device Via the Bluetooth Technology**

When you want to work with the EXFO Exchange mobile application jobs, perform tasks such as generate reports, or configure Wi-Fi networks to receive updates for your unit, you will use Bluetooth® communication. By default, it is disabled on your unit, so you will have to enable before trying to connect to a smart device.

**Note:** *To save battery power, you may wish to disable the Bluetooth communication when you do not use it.*

On your AXS Handheld OTDR unit, the status of the Bluetooth communication is indicated with an icon in the title bar.

<b>Icon</b>	<b>Meaning</b>
Not visible	The Bluetooth communication is disabled.
	The Bluetooth communication is enabled, but no connection has been established yet between the unit and a smart device.
	A connection has been established between the unit and a smart device.

## Working With the EXFO Exchange mobile application

### Enabling or Disabling a Connection With a Smart Device Via the Bluetooth Technology

---

#### To enable the Bluetooth connection:

1. From the main window, use the sliding menu and select **Bluetooth**.

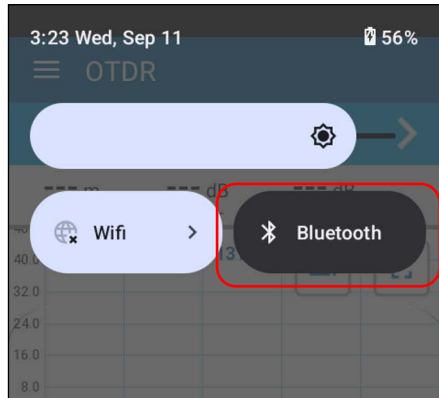

2. If it is not already done, authorize the EXFO Exchange mobile application to access your smart phone's location. Otherwise, you will not be able to access the list of AXS Handheld OTDR units. Access the list of available units and link your unit to the application.

**Note:** *You do not need to connect to a EXFO Exchange mobile application account to establish the connection between your unit and a smart device. You can proceed without entering an ID.*

**Note:** *Refer to the EXFO Exchange mobile application user documentation for more information on using the application.*

The application establishes the communication automatically. When the connection is successful, the  icon appears in the title bar of your AXS Handheld OTDR unit.

**Note:** *The AXS Handheld OTDR can only have one active connection with a smart device at a time.*

## Working With the EXFO Exchange mobile application

*Enabling or Disabling a Connection With a Smart Device Via the Bluetooth Technology*

---

### **To disable Bluetooth on your unit:**

1. From the main window, swipe down from the top to display the sliding menu.
2. Tap **Bluetooth** to disable it.

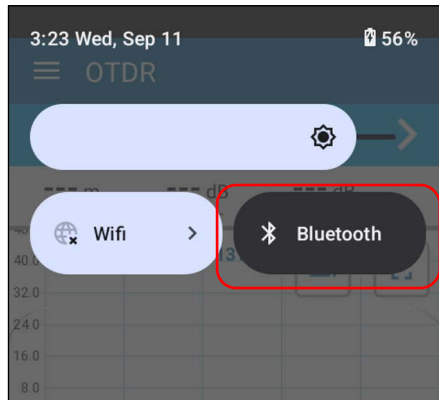

## Enabling or Disabling the Wi-Fi Communication

The interactions between your unit and a smart device are accomplished using the Bluetooth technology and Wi-Fi.

The interactions between your unit and the cloud server as well as the EXFO update server (to retrieve firmware and software updates), are accomplished using a connection to a wireless network.

**Note:** *You can also update your unit using the USB port if you do not have access to Wi-Fi. See Updating the Application on page 178.*

**Note:** *By default, Wi-Fi is not enabled on your unit.*

If you do not intend to use your unit in conjunction with a smart device or do not need to connect to a wireless network for a certain period of time, you may wish to disable the Wi-Fi wireless communication to save battery power.

Once the configuration and first connection are successful, the configured network is automatically added to the list of possible networks on your unit.

The list of configured networks as well as the last network used are kept in memory even when you turn your unit off. This means that the next time you work with your unit, it will automatically connect to the last network used, unless this network is not available or its password has changed in the meantime (reconfiguration necessary). Should a network failure occur while the unit is connected to it, the unit will try to reconnect to this network automatically as soon as it becomes available again.

The list of configured networks as well as the last network used are kept in memory even when you turn your unit off.

You can remove configured networks from the list to prevent automatic connections to these networks. If you remove the network currently in use, the unit will try to connect to the next configured network on the list that is available.

You can remove configured networks from the list to prevent automatic connections to these networks.

Your unit supports IPv4 wireless routers having the following characteristics:

- With dynamic IPv4 address assignment
- Not secured, or secured with WPA/WPA2-Personal standards (WPA-PSK/WPA2-PSK versions)
- Broadcasting their network names (SSID) or not (SSID visible or hidden)
- Configured with a 2.4 GHz Wi-Fi band (b/g/n frequencies).

**Note:** *Your unit does not support the WEP and WPS standards.*

**Note:** *Your unit does not support public Wi-Fi hotspots requiring authentication from a Web page.*



**Note:** *Every work environment has its own specifications. If you need information about the configuration of your router, contact your network administrator.*

## Working With the EXFO Exchange mobile application

### *Enabling or Disabling the Wi-Fi Communication*

---

The information about the Wi-Fi connection is indicated with an icon appearing both in the title bar (on your unit) and next to the name of the wireless networks.

Icon	Meaning
No Wi-Fi icon visible in the title bar	The Wi-Fi communication is disabled.
Faint Wi-Fi icon visible in the title bar 	The Wi-Fi communication is enabled, but the unit is not connected to any wireless network.
	The portion of the icon that appears in white (title bar) or in dark gray (list of wireless networks) reflects the strength of the signal.
	Password-protected (secured) networks are identified by a lock.

## Working With the EXFO Exchange mobile application

### Enabling or Disabling the Wi-Fi Communication

---

**To enable the wireless communication from your unit:**

1. From the main menu, tap  .
2. Scroll down to the **Device settings** section.
3. Tap **Wi-Fi**.

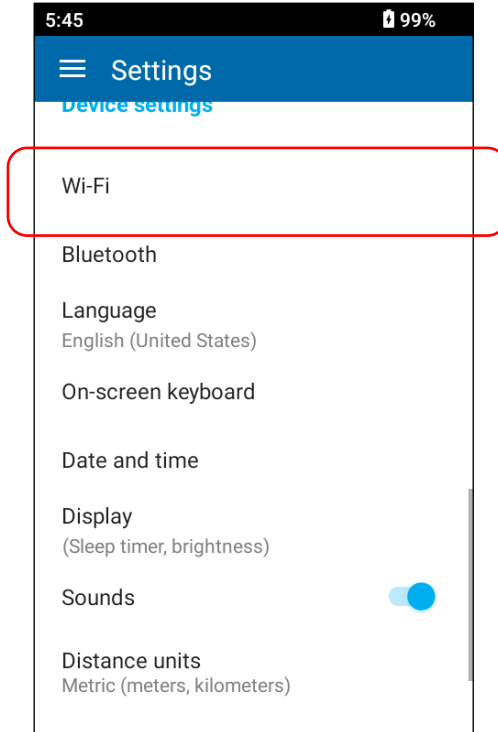

## Working With the EXFO Exchange mobile application

### Enabling or Disabling the Wi-Fi Communication

---

4. Tap on **Wi-Fi** to enable it.

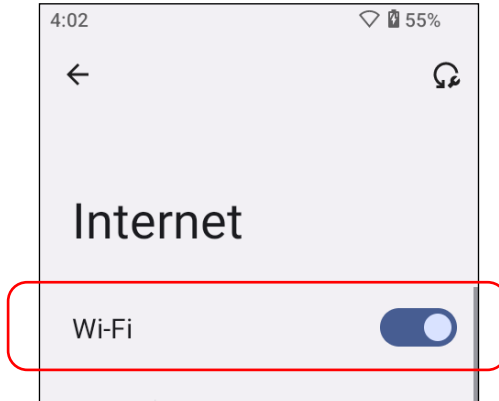

5. Tap the item corresponding to the wireless network that you want to connect to.

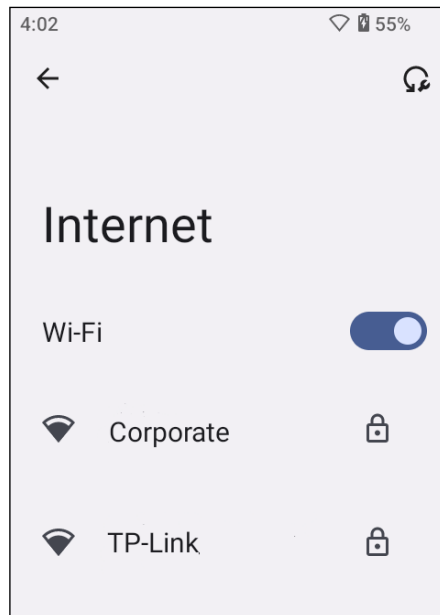

## Working With the EXFO Exchange mobile application

### Enabling or Disabling the Wi-Fi Communication

---

6. If the network is protected by a network security key (password), enter it.

The application establishes the communication automatically.

**Note:** You can also use the sliding menu in the main window to access the Wi-Fi setup page.

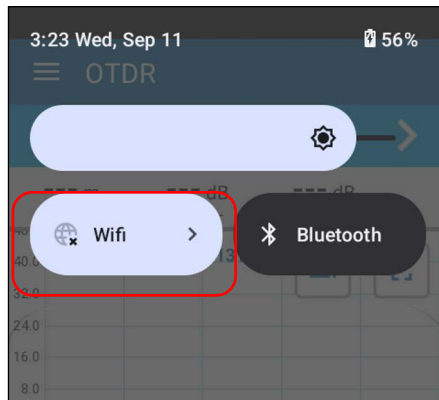

### To remove a configured network from the list from the AXS Handheld OTDR:

1. From the main menu, tap  .
2. Scroll down to the **Device settings** section.
3. Tap **Wi-Fi**.

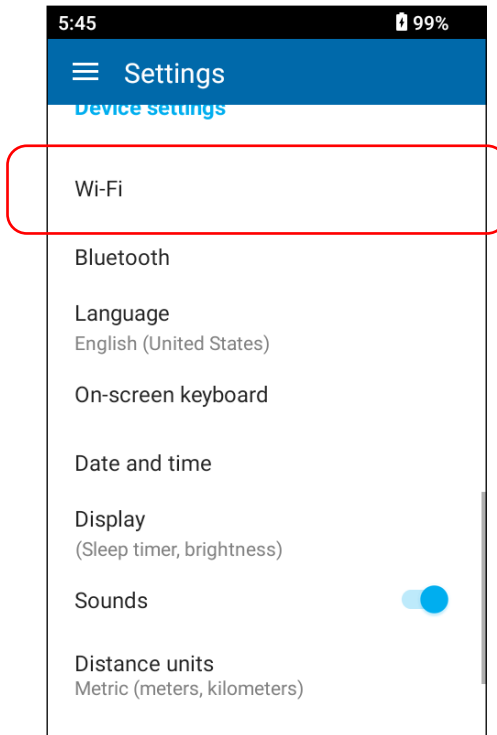

4. Tap the wireless network that you want to remove to access its details page.
5. Tap **Forget**.

The network is removed from the list automatically. If these networks are still in range, they will reappear on the list of available networks.

## **Synchronizing Job Results With the Smart Device and the Cloud Server**

The EXFO Exchange mobile application manages the measurements associated with jobs automatically for you.

The synchronization process begins as soon as a Bluetooth connection is established between your unit and the smart device. Test results are sent to the mobile application to allow report creation without filling the smart device's memory. By sending the results to the EXFO Exchange mobile application, you can synchronize the entire job or the tests already done in a job. This way, you can resume a job that has already been started by someone else on another unit and transfer it to the AXS Handheld OTDR you are using for your tests. You cannot view the details for the tests already completed and transferred to another unit.

The following types of data can be synchronized:

- **Summary:** includes the name, pass/fail verdict, element table with losses and reflectances, which will be used to see the results on the viewer.
- **Complete:** includes the raw data which includes the traces. This type of data can be used in a post-processing software like FastReporter 3 for further analysis.
- **Status data:** this type of data will be sent to the unit from the smart device when a cloud job was already started on another unit. It only includes the pass/fail verdict and a timestamp.

Both summary and complete data are synchronized using Bluetooth, with priority given to the summary data. For a faster transfer, use a Wi-Fi connection instead.





## Working With the EXFO Exchange mobile application

### *Synchronizing Job Results With the Smart Device and the Cloud Server*

---

The icon next to the job name indicates the current synchronization status of each job with the cloud server. The table below shows the different possible synchronization statuses and their respective meanings.

Once the results are synchronized, they are marked as such in the list of measurements both on the smart device and on your unit.

Icon	Meaning
	<ul style="list-style-type: none"><li>➤ All test results have their complete data exported to the smart device.</li><li>➤ No tests have been performed in the job.</li></ul>
	<ul style="list-style-type: none"><li>➤ All test results in the job have their summary data exported to the smart device.</li><li>➤ At least one test result in the job has not exported its complete data to the smart device.</li></ul>
	<ul style="list-style-type: none"><li>➤ At least one test result in the job has not exported its summary data to the smart device.</li><li>➤ At least one test result in the job has not exported its complete data to the smart device.</li></ul>
	At least one test result in a job is in the process of exporting its summary or complete data to the smart device.

When a synchronization is in progress with the smart device or the cloud server, no data is lost if the battery level of the unit is too low or your AXS Handheld OTDR is disconnected from the Wi-Fi network. The synchronization process resumes once the AXS Handheld OTDR is connected to a power outlet and a Wi-Fi connection is established.

## 10 Maintenance

To help ensure long, trouble-free operation:

- Always inspect fiber-optic connectors before using them and clean them if necessary.
- Keep the unit free of dirt and dust.
- Clean the unit casing and front panel with a cloth slightly dampened with water.
- Store unit at room temperature in a clean and dry area. Keep the unit out of direct sunlight.
- Avoid high humidity or significant temperature fluctuations.
- Avoid unnecessary shocks and vibrations.



### **WARNING**

The use of controls, adjustments and procedures, namely for operation and maintenance, other than those specified herein may result in hazardous radiation exposure or impair the protection provided by this unit.

## Cleaning Optical Connectors Using a Mechanical Cleaner

Optical connectors are fixed on your unit and can be cleaned using a mechanical cleaner.



### WARNING

Verifying the surface of the connector with a fiber-optic microscope **WHILE THE UNIT IS ACTIVE WILL result in permanent eye damage.**



### CAUTION

If you are cleaning an EUI with a mechanical cleaner, do not remove it from your device to clean it.

#### ***To clean a connector using a mechanical cleaner:***

1. Insert the cleaning tip into the optical adapter, and push the outer shell into the cleaner.

**Note:** *The cleaner makes a clicking sound to indicate that the cleaning is done.*

2. Verify connector surface with a fiber inspection probe (for example, EXFO's FIP).

## Cleaning the Touchscreen

Clean the touchscreen with a soft, non-abrasive cloth, such as one used for cleaning reading glasses, dampened with water.



### CAUTION

Using anything else than water can damage the special coating of the touchscreen.

## Recharging the Battery

Your unit uses one lithium-polymer (Li-Po) battery.

- The charge status is shown in the upper right corner of the title bar. A red icon indicates that the battery level is running low and that you should connect the unit to a power outlet. For more information, see *Battery Status Icon Description* on page 6.
- The unit also indicates the charge status with the LED on its front panel (see *LED Indicator Description* on page 5).



### CAUTION

Only charge the battery with the USB power adapter provided by EXFO with your unit.



### CAUTION

The device is compliant with USB 2.0 and USB 3.0 power specifications for input current and voltage regulation and meets USB On-the-Go (OTG) operation power rating specification with constant current limit up to 3.2 A.



## **IMPORTANT**

- The battery is not charged at the factory. You must fully charge it before using the unit for the first time. The battery is fully charged after a few hours or when the battery LED indicator is steady blue.
- The time required to charge the battery depends on various factors such as the type of tests currently performed and the ambient temperature.
- To ensure that the battery functions properly, keep it in temperatures between  $-10\text{ }^{\circ}\text{C}$  and  $45\text{ }^{\circ}\text{C}$  ( $14\text{ }^{\circ}\text{F}$  and  $113\text{ }^{\circ}\text{F}$ ). Store it between  $10\text{ }^{\circ}\text{C}$  to  $35\text{ }^{\circ}\text{C}$  ( $50\text{ }^{\circ}\text{F}$  to  $95\text{ }^{\circ}\text{F}$ ).  
When the ambient temperature is below  $0\text{ }^{\circ}\text{C}$  ( $32\text{ }^{\circ}\text{F}$ ) or when it reaches or exceeds about  $40\text{ }^{\circ}\text{C}$  ( $104\text{ }^{\circ}\text{F}$ ), the battery can either charge more slowly than usual, or not charge at all, depending on the internal temperature of your unit.
- Do not leave a battery discharged for several days.
- After 300 cycles (approximately 18 months of use), you may want to replace the battery with a new one to maintain optimal operation conditions. Otherwise, the operating time might be reduced.



## IMPORTANT

- If you need to store the unit (or a battery) for an extended period of time, ensure that the battery is charged at around 50 % of its capacity, and then turn the unit off (shutdown).
- Place the unit (or the battery) in a cool dry place, and ensure that the battery is charged at around 50 % of its capacity. Every three months during the storage period, verify the battery level. Recharge the battery when necessary, so that its charge level remains around 50 % of the total capacity. This will ensure that you get the optimum performance out of the battery.

### **To recharge the battery:**

Connect the unit to a power outlet using the USB power adapter (fastest way to charge the battery).

**Note:** *The standard USB ports of a computer cannot power your unit or charge its battery while the unit is on. If you connect your unit to such a USB port with the USB cable, the unit will still consume battery power. If the unit is off when you connect it to the USB port of a computer, its battery could charge, but slowly.*

**Note:** *If you have a vehicle equipped with dedicated USB charging ports, you could connect your unit to one of these ports to charge the battery. The actual results will vary with each vehicle. You could also use a certified USB power bank (portable charger) to charge your unit.*

The charge cycle will start and end automatically.

**Note:** *The clock battery also recharges when the unit is connected to an external power source if the unit is on or in sleep mode.*

## Battery Maintenance Recommendations



### **WARNING**

Your unit uses the following type of batteries: smart lithium-polymer (Li-Po).

These are batteries with built-in protection that have been especially designed for EXFO. For this reason, you can only replace them with EXFO-approved batteries of the same type and model.



### **WARNING**

The use of incorrect type or unapproved batteries may result in explosion or the batteries expanding or igniting (that is, catching fire).



### **WARNING**

Do not throw batteries into fire or water and do not short-circuit their electrical contacts. Do not disassemble.



### **IMPORTANT**

Recycle or dispose of used batteries properly, according to the manufacturer's instructions and in accordance with local regulations. Do not dispose of them in ordinary garbage receptacles. For more information, see the section about recycling and disposal in this user documentation.

- At EXFO, we take the safety of our customers very seriously and want to make sure any battery replacement is done properly.

The batteries of all EXFO-branded products are tested, certified, and in compliance with these international safety standards:

- ❖ United Nations (UN) Transport Regulations UN38.3: Covers battery safety during air transport.
  - ❖ UL 61010-1, CAN/CSA C22.2 61010-1 and International Standard IEC/EN 61010-1: Covers the use of batteries for test and measurement equipment.
  - ❖ International Standard IEC 62133: Covers secondary cells and batteries containing alkaline or other non-acid electrolytes.
  - ❖ In some countries, when required, EXFO-approved batteries have been certified and are marked as per local regulation.
- To get pricing and correct part number for replacement batteries for your products, please contact (via email):
    - ❖ For Americas: [Isales.us@exfo.com](mailto:Isales.us@exfo.com)
    - ❖ For Europe: [Isales.emea@exfo.com](mailto:Isales.emea@exfo.com)
    - ❖ For APAC: [Isales.apac@exfo.com](mailto:Isales.apac@exfo.com)
    - ❖ For China: [Isales.China@exfo.com](mailto:Isales.China@exfo.com)
  - You may also obtain replacement batteries for your products by contacting your local distributor:  
<https://www.exfo.com/en/how-to-buy/find-distributor>
  - You may return your unit for service at your local service center:  
<https://www.exfo.com/en/services/field-network-testing/exfo-service-centers/>

## Replacing the Battery

Your unit can be powered either by battery or from an appropriate power outlet when used with the provided USB power adapter.

For more information on the available power sources for your unit, as well as their characteristics, refer to the *Technical Specifications* of your product.



### CAUTION

Electrostatic discharge (ESD) damage can cause complete or intermittent equipment failures.

- Always use an ESD-preventive wrist or ankle strap when replacing the battery. Ensure that the antistatic strap makes good skin contact and that the end of its wire is grounded properly.
- Never touch any component inside the unit other than those identified in the procedure hereafter, either with tools or your fingers.

**Note:** *When you change the battery, you will need to set the date and time again.*

**Note:** *Your unit will turn on automatically after you change the battery. This is not a safety issue, as the lasers will not turn on automatically.*

**To replace the battery:**

- 1.** Turn off the unit (shutdown) and disconnect the fiber and USB cable (if applicable).
- 2.** Position the unit so that its front panel rests on a flat surface such as a table.
- 3.** On the back of the unit, using a 2.5 mm hex socket screwdriver, turn the screws (4) counterclockwise until they are loose, and remove them.

Turn screws  
counterclockwise

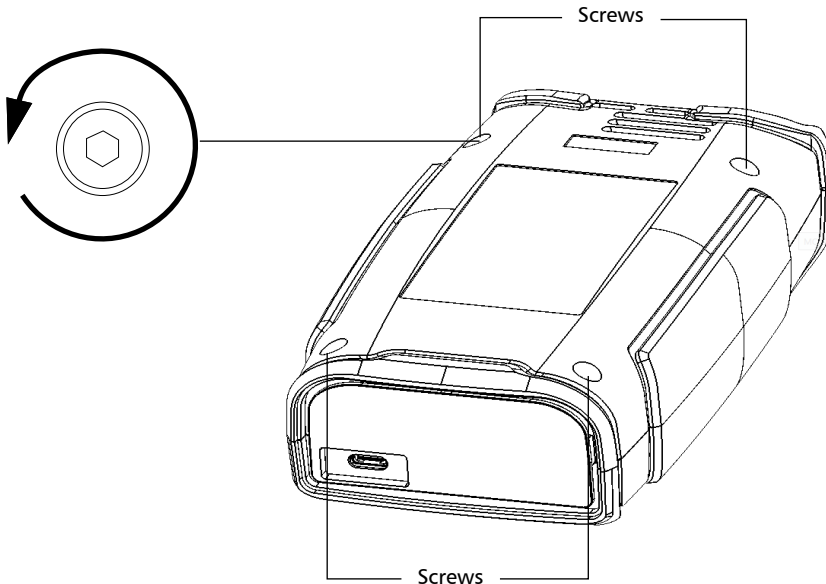

4. Hold the back panel by its sides and pull it up to remove it.

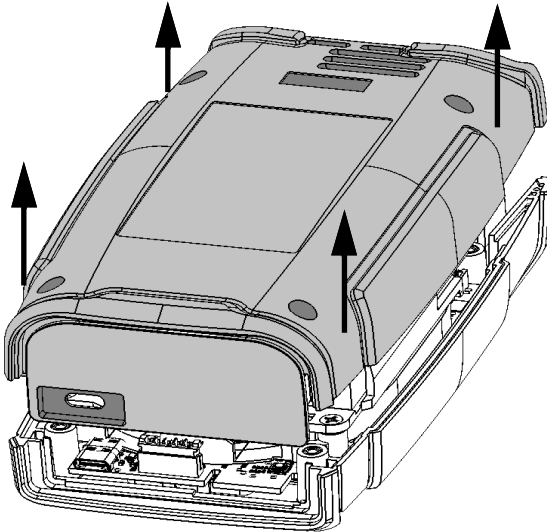

5. Gently pull on the battery's connector to disconnect it from its socket.

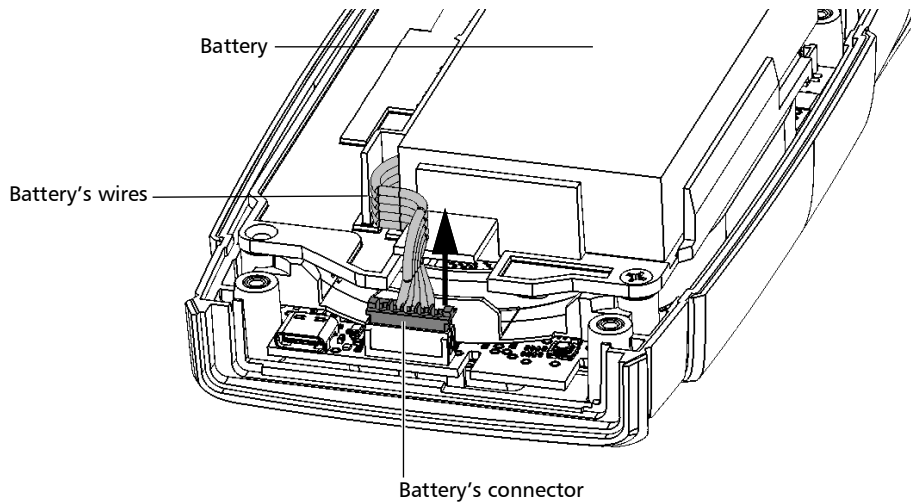

6. Pull the battery up to remove it.

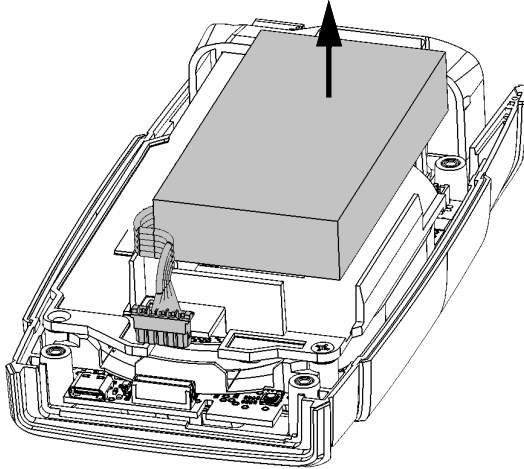

7. Place the new battery so that its wires are located on the left side, toward the front.

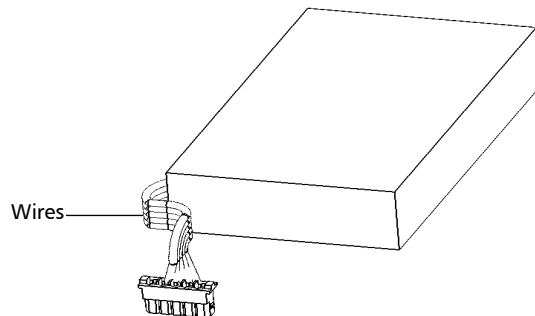

8. Push the new battery toward the bottom of the case until it stops.

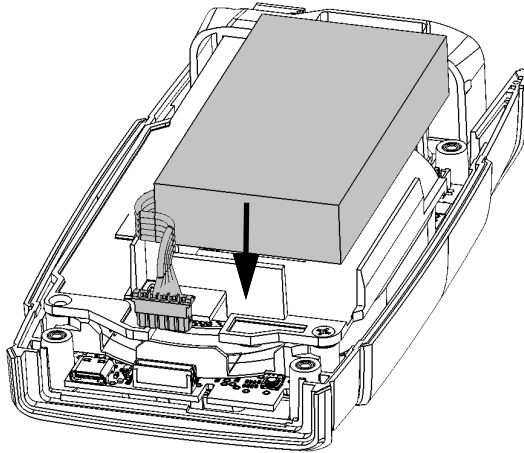

9. Ensure that the battery's wires are *above* the plastic tab (not under), and then connect the battery's connector to the corresponding socket.

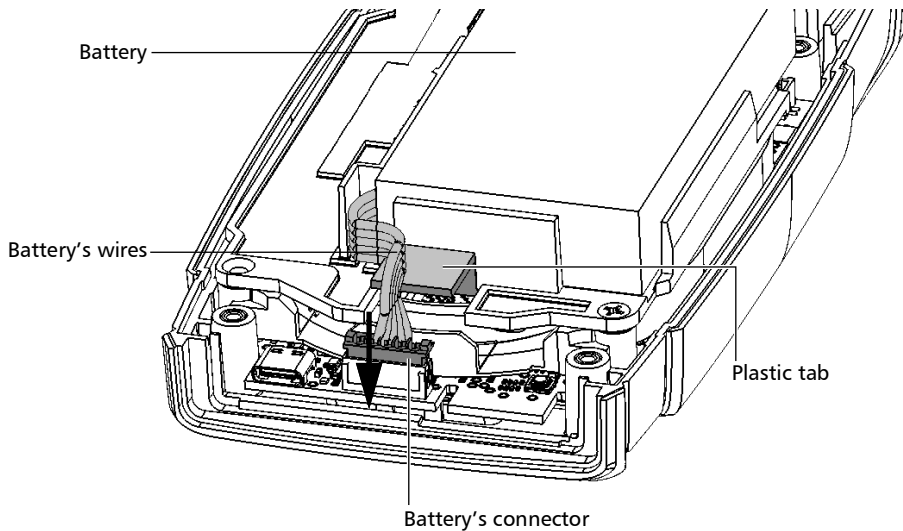

- 10.** Place the back panel on the unit, making sure that it is aligned properly with the front of the unit. The sides of the back panel should be flush with those of the front. There should be no gap between the back panel and the front of the unit. If necessary, slightly move the back panel until alignment is correct.

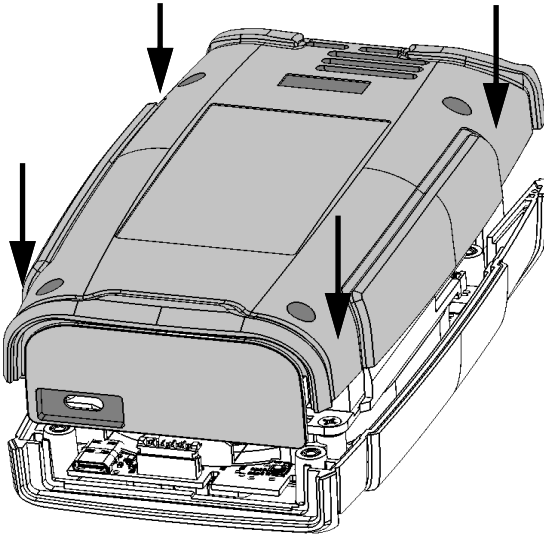

- 11.** Using a 2.5 mm hex socket screwdriver, turn the screws (4) clockwise until they are tightened.

This will secure the back panel into place.

## Verifying the Optical Output of Your Unit

Your unit comes with a wizard that verifies the optical output and provides you with information about the condition of the external and the internal optical connectors.

Once its verification is complete, the wizard rates the result from zero to five stars (half-stars are possible). Any verification receiving a three-star rating or less requires your attention. This can help you determine if the optical connectors are still working properly or if a replacement is necessary.



### CAUTION

To ensure that the internal optical connection remains in the best condition possible, **DO NOT REMOVE** the Click-Out connector from your unit unless it is absolutely necessary.



### IMPORTANT

Your unit has been designed not to require frequent calibrations (see *Recalibrating the Unit* on page 181). However, to ensure that the performance of your unit remains optimum, EXFO recommends to perform regular optical output verifications on it.

**To verify the optical output of your unit:**

1. Inspect and clean the unit's optical port.
2. If the port is damaged, replace the Click-Out connector (see *Replacing the Click-Out Optical Connector* on page 175). If the port is damaged and your unit is not equipped with a Click-Out connector, contact EXFO (see *Service and Repairs* on page 205).

OR

If the port seems fine, continue with the remaining steps of this procedure.

3. Inspect and clean the connector of the launch fiber that you will be connecting to the optical port during the verification process.
4. From the main menu, tap .
5. Tap **Optical output diagnosis**.

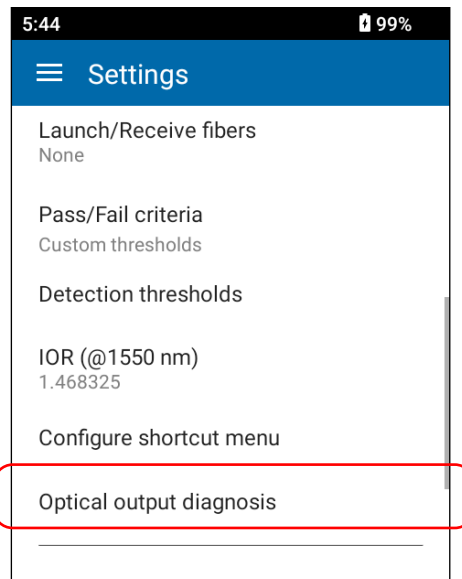

6. Follow the on-screen instructions.

**Note:** During the verification process, you will connect one end of the launch fiber to the optical port of your unit. The other end of the cord must remain unconnected.

7. Connect the test cord to the optical port of your unit, select your connector type, and then tap the arrow button.

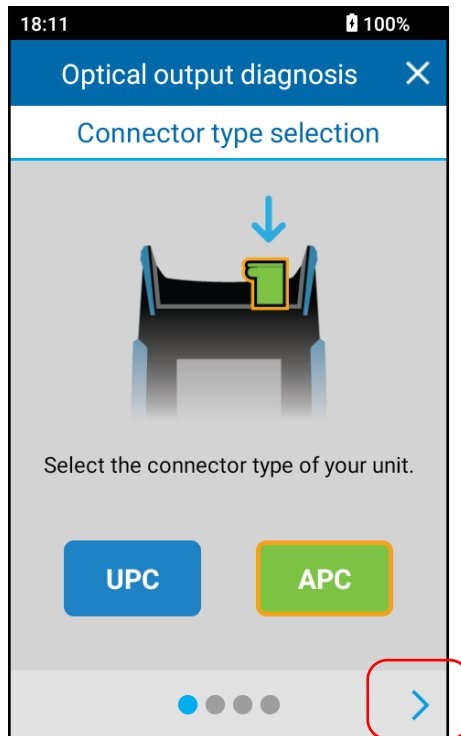

Once the test is complete, the unit displays the result of the verification as well as recommendations, when applicable. If you have finished your work, tap the exit arrow. If you want to perform the verification again, tap **BACK** from the lower left corner of the screen.

**Note:** *The internal optical connection could have been degraded by an inappropriate handling of the Click-Out connector. If you want to perform additional verifications on your unit before sending it for repair, see Performing Additional Verifications on Your Unit’s Connectors on page 188.*

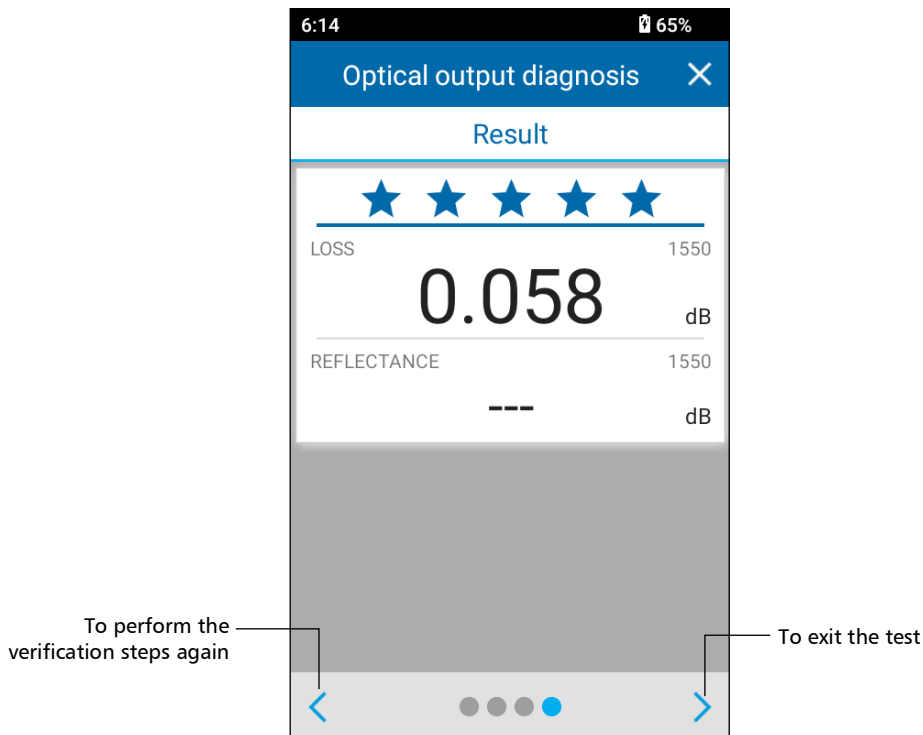

## Replacing the Click-Out Optical Connector

All units come with a Click-Out optical connector that you can replace should you need a different connector type (APC or UPC), or should it become damaged with time. You can purchase new Click-Out connectors from EXFO.

**Note:** *You cannot change or repair the internal connector yourself.*

If your unit is not equipped with a Click-Out optical connector and the connector has to be replaced, you need to contact EXFO (see *Service and Repairs* on page 205).

### **To remove the Click-Out optical connector:**

1. Turn off the unit (shutdown).
2. Disconnect the fiber and USB cable from the unit, if applicable.
3. Position the unit so that you can see its Click-Out connector and easily access it.

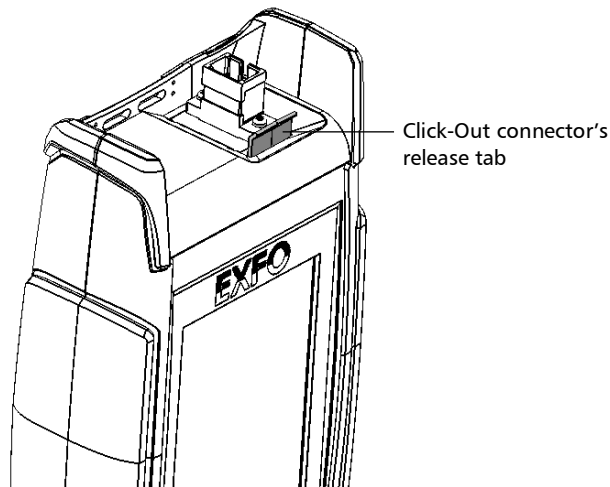

4. While pushing the release tab toward the back of the unit, pull the Click-Out connector out of the unit.

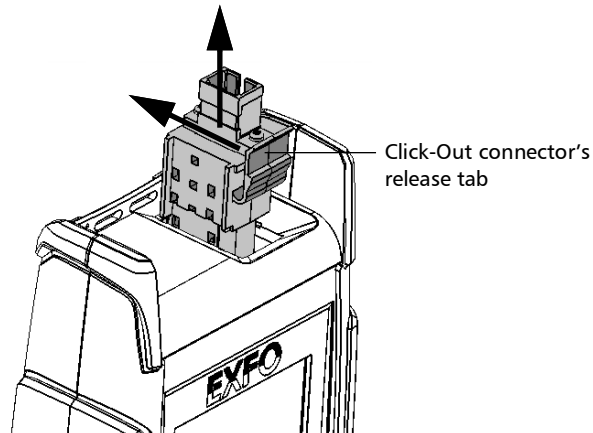

#### **To replace (or reinstall) the Click-Out optical connector:**

1. Position the new Click-Out connector vertically so that you can see its release tab and that the optical port is pointing upwards.

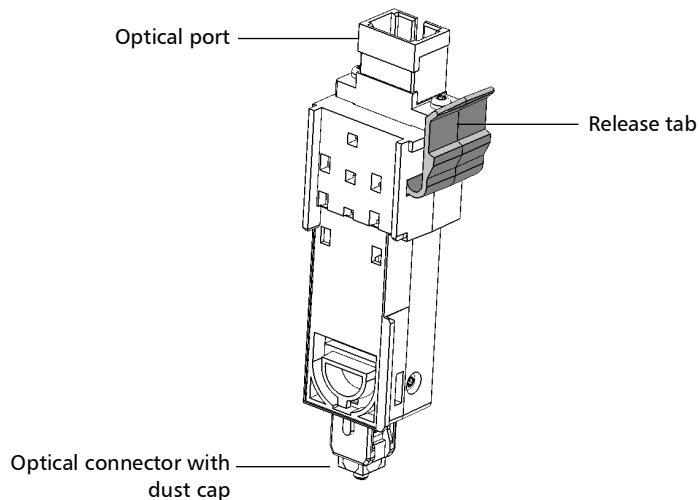

2. Remove the dust cap protecting the optical connector (which should be pointing downwards), being careful not to touch the optical connector.
3. Inspect the optical connector (from which you have just removed the dust cap), and clean it if necessary.
4. Slide the Click-Out connector into the unit until it clicks into place.

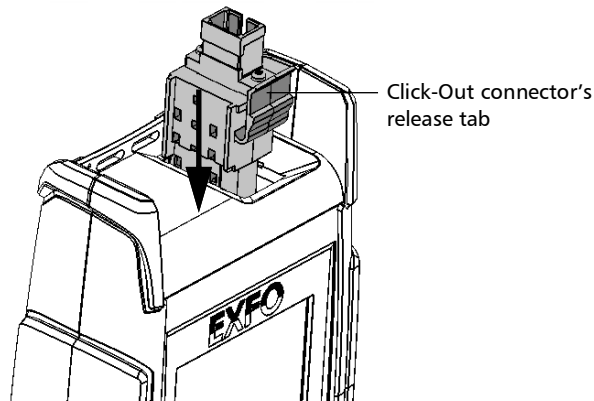

There should be no gap between the edges of the Click-Out connector and its bay when it is inserted properly.

5. Inspect and clean the optical port if necessary.
6. Turn on the unit.
7. Perform an optical output verification to ensure that the new Click-Out connector is installed properly and that the unit takes into account the right connector type (see *Verifying the Optical Output of Your Unit* on page 171).

**Note:** *If the optical output verification detects issues, see the step about how to clean the internal connector in Determining the Condition of the Click-Out Optical Connector on page 188.*

Your unit is ready to use.

## Updating the Application

The application on your unit has been preinstalled and configured at the factory. However, you may have to update it when new versions become available. Your unit allows you to check for updates, download these updates and install them directly. You can update your unit using the Wi-Fi connection or by connecting to a computer or USB storage using the USB port.



### IMPORTANT

The update can take a few minutes.

- Do not turn the unit off while it is updating.
- Make sure you have sufficient battery power for the update, as you cannot use the USB port during the procedure.
- If a USB stick is used to perform the update, your unit will prioritize it over the Wi-Fi method, even if the Wi-Fi connection is active and available.

## Updating Using Wi-Fi



### IMPORTANT

For a trouble-free update, ensure that you connect your unit to a power outlet and that your unit remains on during all the process.

#### **To update the application:**

1. Connect your unit to an external power source with the provided USB power adapter.
2. If it is not already done, turn on your unit.
3. Ensure that your unit has access to a Wi-Fi network for the whole duration of the update (see *Enabling or Disabling the Wi-Fi Communication* on page 149 for details).
4. From the main menu, tap .

5. Under **Unit settings**, tap **Update**.

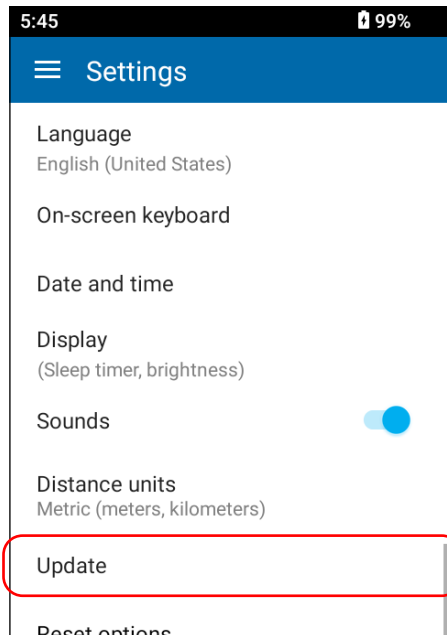

6. The unit will look for an available update. If it finds one, you can tap **Update** to proceed with the installation.

**Note:** *The update can take a few minutes to complete.*

**Note:** *The unit will restart after the update.*

## Updating Using the USB Connection

If you do not have access to Wi-Fi, you can use the USB port to install updates on your unit.

### To update the application:

1. Copy the update file provided by your sales partner onto the root of a USB key. The key must be formatted in the FAT32 format.
2. From the main menu, tap .
3. Under **Device settings**, tap **Update**.

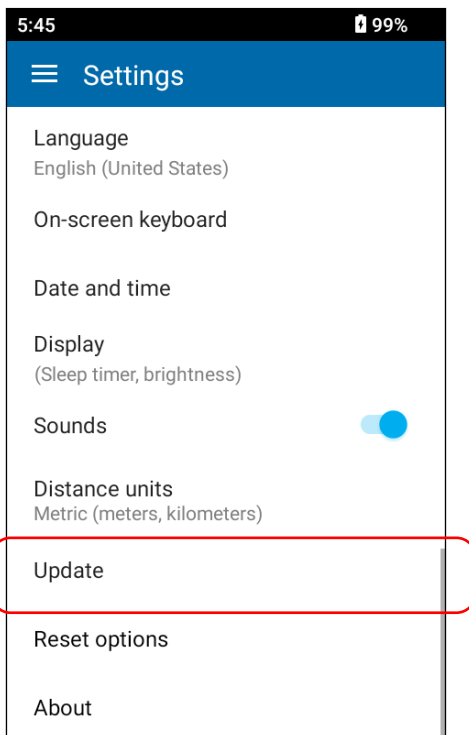

4. Your unit will search for the update on the USB drive and prompt you to accept the update.

Once the update is complete, the unit restarts automatically.

## Recalibrating the Unit

EXFO manufacturing and service center calibrations are based on the ISO/IEC 17025 standard (*General Requirements for the Competence of Testing and Calibration Laboratories*). This standard states that calibration documents must not contain a calibration interval and that the user is responsible for determining the re-calibration date according to the actual use of the instrument.

The validity of specifications depends on operating conditions. For example, the calibration validity period can be longer or shorter depending on the intensity of use, environmental conditions and unit maintenance, as well as the specific requirements for your application. All of these elements must be taken into consideration when determining the appropriate calibration validity period of this particular EXFO unit.

Until you collect the required empirical data to support your own calibration interval strategy, EXFO recommends that the next calibration (due) date of an instrument be established according to the following equation:

**Next calibration date = Date of first usage + Recommended calibration period (one year)**

**Note:** *You can use the date of first usage only if the product was stored in proper conditions (23 °C ± 5 °C (73,4 °F ± 9 °F)). If it is not the case or if you do not know the date of first usage, you can use the date at which you received the product, as long as the product was sourced from an official EXFO distribution channel.*

Restriction:

Next calibration date ≤ calibration date on certificate + recommended calibration period (one year) + maximum storage period (one year)

Under normal use, the recommended calibration period for your AXS Handheld OTDR is: one year.

For newly delivered units, EXFO has determined that the maximum storage period for this product is up to one year.

EXFO guarantees that proper storage at room temperature for up to the maximum storage period between calibration and shipment will not affect the performance of the test and measurement instruments and will not reduce the recommended validity period before requiring a new calibration.

To help you with calibration follow-up, EXFO provides a special calibration label that complies with the ISO/IEC 17025 standard and indicates the unit calibration date and provides space to indicate the due date.

To ensure that test and measurement instruments conform to the published specifications, calibration must be carried out at the relevant EXFO plant, or, depending on the product, at an EXFO service center, or at one of EXFO's certified service centers. All calibrations are performed using standards traceable to national metrology institutes.

**Note:** *You may have purchased a FlexCare plan that covers calibrations. See the Service and Repairs section of this user documentation for more information on how to contact the service centers and to see if your plan qualifies.*

## Recycling and Disposal



This symbol on the product means that you should recycle or dispose of your product (including electric and electronic accessories) properly, in accordance with local regulations. Do not dispose of it in ordinary garbage receptacles.

For complete recycling/disposal information, visit the EXFO Web site at [www.exfo.com/recycle](http://www.exfo.com/recycle).

# 11 Troubleshooting

## Solving Common Problems

Problem	Possible Cause	Solution
My unit does not start.	The battery is completely discharged (if the battery level allows it, the unit's LED will remain red for about 10 seconds when you try to turn on the unit).	Connect the unit to an external power source to recharge the battery. If the battery is no longer charging properly, you may need to replace it with a new one (see <i>Replacing the Battery</i> on page 165).
	The system has encountered a problem.	Press the on/off button for at least ten seconds to force a hardware reset on the unit.  If the problem persists, restore your unit to normal operation (see <i>Using the Recovery Mode on Your Unit</i> on page 194).
	Some files essential to the normal operation of the unit have been corrupted.	Press the on/off button for up to 20 seconds to force a hardware reset on the unit.  If the problem persists, try resetting the AXS Handheld OTDR to its factory settings (see <i>Resetting Your Unit Settings and Data</i> on page 81).  If the problem still persists, restore your unit to normal operation (see <i>Using the Recovery Mode on Your Unit</i> on page 194).
My unit is not responding.	The system has encountered a problem.	Press the on/off button for at least ten seconds to force a hardware reset on the unit.

<b>Problem</b>	<b>Possible Cause</b>	<b>Solution</b>
The battery is not recharging.	Ambient temperature is too high or too low.	In this case, the unit's LED is blue and blinks slowly.  Make sure that the temperature in the location where you recharge the battery is within the specifications.
	The USB power adapter is not connected properly.	Make sure that the USB power adapter is connected to the unit and the AC outlet.  In this case, the unit's LED is not blinking at all, but there is a battery icon with a flash symbol displayed on screen.  If the USB power adapter is connected properly and the problem persists, it could mean that the USB power adapter is defective. In this case, try replacing the adapter. You can purchase new USB power adapters from EXFO.
	The system has encountered a problem.	Press the power button for at least two seconds or until the unit beeps and the LED turns white to try to connect again. If the problem persists, contact your provider.

Problem	Possible Cause	Solution
I have just replaced the battery and the unit's LED turns to red when I turn on the unit.	The unit may take a little time to detect the level of a new battery.	Connect the unit to a power outlet with the provided USB power adapter and let the battery charge for a few minutes. After a short while, the unit should turn on. However, it could take a few charge/discharge cycles before the unit's LED indicator and the on-screen battery status icon reflect the actual power level of the new battery.
On my unit, no wireless network is listed.	No network has been configured yet.	You must first configure the desired networks on your unit or on the smart device using the EXFO Exchange mobile application.
My unit does not connect automatically to the wireless network that I have used during my last work session.	There is a connection problem with the network.	<ul style="list-style-type: none"> <li>➤ Ensure that the Wi-Fi connection is enabled on your unit (see <i>Enabling or Disabling the Wi-Fi Communication</i> on page 149).</li> <li>➤ In the case of a secured network, ensure that the password has not changed since the initial configuration of this network. If the password is no longer valid, you will have to update it on your unit or by using the EXFO Exchange mobile application.</li> <li>➤ Ensure that the network is working normally.</li> </ul>
I cannot delete a job.	The job you want to delete is the active job.	To delete a job, you must first select another job to make it the active job.

Problem	Possible Cause	Solution
The unit does not see the USB drive connected to the port.	The key was formatted in NTFS format, which is not compatible with this system.	Change the formatting to FAT32 or use a different USB drive.
I cannot enable Wi-Fi and Bluetooth connections.	Your unit does not have wireless capabilities.	You must use a unit that has wireless capabilities to enable Wi-Fi and Bluetooth connections.
My unit does not connect to the wireless network that I choose from the list of configured networks.	There is a connection problem with the network.	<ul style="list-style-type: none"> <li>➤ Ensure that the Wi-Fi connection is enabled on your unit (see <i>Enabling or Disabling the Wi-Fi Communication</i> on page 149).</li> <li>➤ In the case of a secured network, ensure that the right password has been entered and that it has not changed since the initial configuration of this network. You will have to re-enter the password or update it in your unit or using the EXFO Exchange mobile application.</li> <li>➤ Ensure that the network is working normally.</li> </ul>
My unit cannot connect to a Wi-Fi network even though I have configured all parameters correctly.	Since every network has its own specifications, there may be elements that are not compatible with your unit.	<p>Configure a Wi-Fi hotspot on a smart device or a laptop that you will use to give your unit access a wireless network.</p> <p>When it is done, add this Wi-Fi hotspot to the list of configured networks as you would with any Wi-Fi networks.</p>

<b>Problem</b>	<b>Possible Cause</b>	<b>Solution</b>
I cannot use the EXFO Exchange mobile application anymore.	The SSL certificate is no longer valid.	<ul style="list-style-type: none"><li data-bbox="763 263 1188 451">➤ You need to update the EXFO Exchange mobile application on the smart device and establish a Bluetooth connection with the AXS Handheld OTDR.</li><li data-bbox="763 457 1188 526">➤ If this does not work, contact EXFO.</li></ul>

## Performing Additional Verifications on Your Unit's Connectors

Before sending your unit for repair, you may want to perform additional verifications.

### Determining the Condition of the Click-Out Optical Connector

You can check if there is a problem with the Click-Out connector on your unit and you need to replace it.

#### **To determine if the Click-Out connector needs to be replaced:**

1. Remove the Click-Out connector from the unit (see the corresponding procedure in *Replacing the Click-Out Optical Connector* on page 175).
2. Clean and inspect the optical port and the optical connector that connects inside the unit.

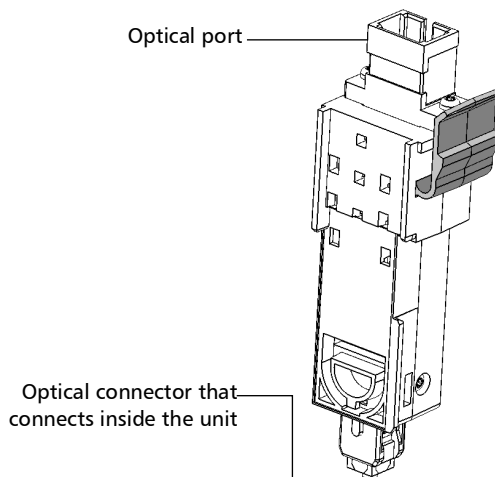

3. If the port or the connector is damaged, replace the Click-Out connector (see *Replacing the Click-Out Optical Connector* on page 175).

OR

If the port and connector seem fine, continue with the remaining steps of this procedure.

4. If desired, from the Click-Out connector bay, clean the internal connector using a 2.5 mm pencil cleaner.

**Note:** *If you do not have a 2.5 mm pencil cleaner, you can use a dry lint-free swab.*

5. Place the Click-Out connector back in the unit (see the corresponding procedure in *Replacing the Click-Out Optical Connector* on page 175).
6. Perform an optical output test again as explained in *Replacing the Battery* on page 165.
7. If the ranking remains low (three stars or less), you could repeat the steps above. If after a couple of tries the ranking remains low, it probably means that the internal connector needs to be replaced. In this case, contact EXFO (see *Service and Repairs* on page 205).

## Putting the Internal Connector Back in Place

Regardless of the model of unit that you have, if the unit was dropped, the internal connector may no longer be assembled correctly to the optical circuit. This would cause fail measurements. If you want, you can follow the procedure explained hereafter to help you put the internal connector back in place.

### **To put the internal connector back in place:**

1. Turn off the unit (shutdown) and disconnect the USB cable (if applicable).
2. Position the unit so that its front panel rests on a flat surface such as a table.

3. On the back of the unit, using a 2.5 mm hex socket screwdriver, turn the screws (4) counterclockwise until they are loose, and remove them.

Turn screws  
counterclockwise

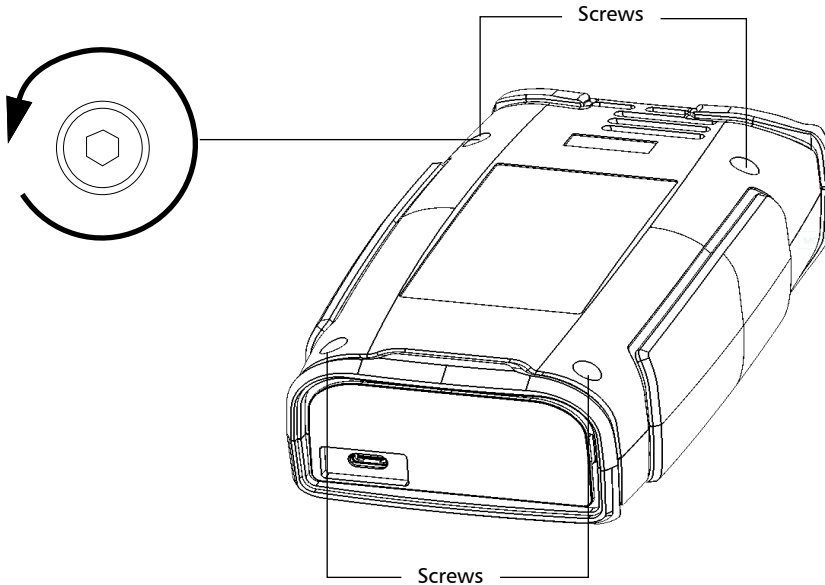

4. Hold the back panel by its sides and pull it up to remove it.

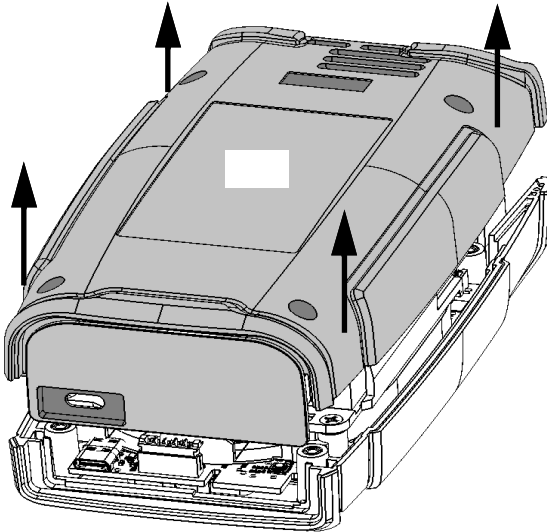

5. If desired, clean the internal optical connector.

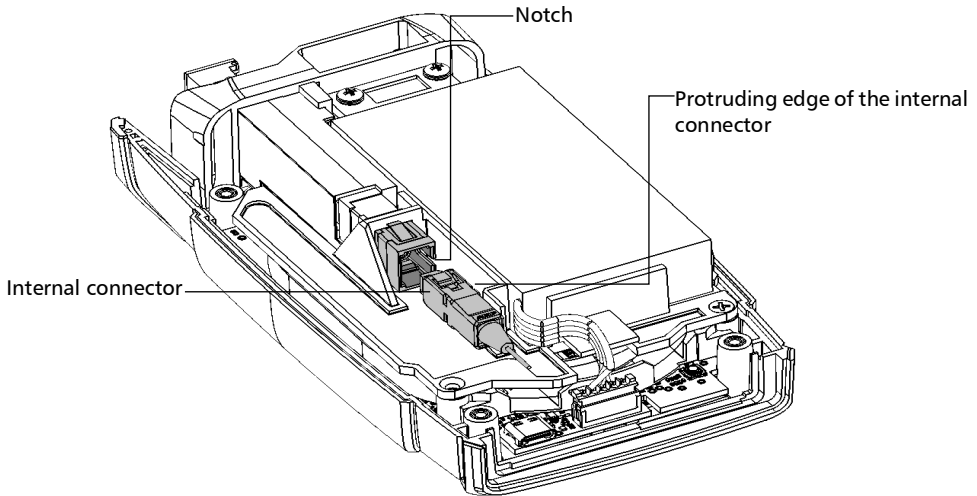

6. Ensure that the protruding edge of the internal optical connector is aligned with the corresponding notch.
7. Gently push the internal connector back in place until you hear a click.

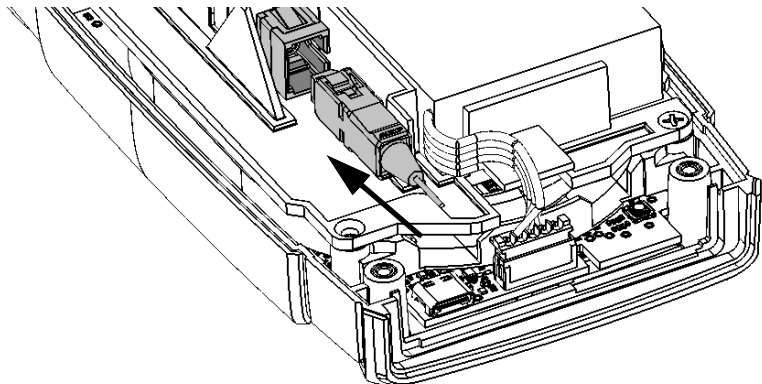

8. Place the back panel on the unit, making sure that it is aligned properly with the front of the unit. The sides of the back panel should be flush with those of the front. There should be no gap between the back panel and the front of the unit. If necessary, slightly move the back panel until alignment is correct.

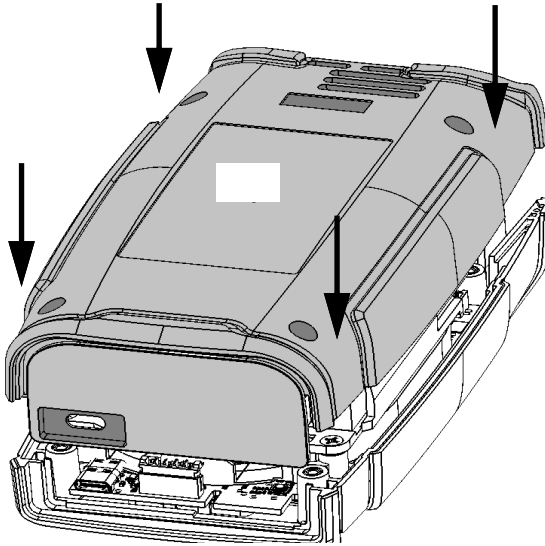

9. Using a 2.5 mm hex socket screwdriver, turn the screws (4) clockwise until they are tightened.

This will secure the back panel into place.

If the ranking is low (three stars or less), it probably means that your unit needs repairs. In this case, contact EXFO (see *Service and Repairs* on page 205).

## Using the Recovery Mode on Your Unit

If you ever encounter major problems with your unit (for example, the unit does not behave the way it used to), you can use the recovery mode to attempt to solve the problem. You can perform the following actions in the recovery mode:

- Reboot the system: this will restart the unit.
- USB update: this will update the unit using a file you have put on a USB drive and connect to the port.
- Wipe the data and perform a factory reset: this option will erase all of the data on the unit but keeps the latest version of the system and application that were installed on the unit.



### **CAUTION**

- **Once the reset operation is started, it cannot be canceled. Make sure to transfer any data that you wish to keep prior to starting the recovery operation, as they will be permanently lost. Data transfer is only possible for units used in conjunction with the EXFO Exchange mobile application through the synchronization process. See *Synchronizing Job Results With the Smart Device and the Cloud Server* on page 156.**
- **As indicated in the procedure below, before starting the recovery operation, connect your unit to a power outlet using the provided USB power adapter.**
- **Follow the procedure below carefully and connect your unit to a power outlet using the provided USB power adapter when you are instructed to do so.**

#### **To use the recovery mode on your unit:**

1. Ensure that the battery level of your unit will be sufficient to start the unit when instructed to do so (no red battery icon on screen or red, steady LED on the unit's front panel).
2. Turn off your unit (shutdown).
3. If applicable, disconnect the USB cable.



### **CAUTION**

To avoid damaging your unit, do not use metallic objects such as the ball of a pen to push the reset button. Always use a non-metallic object.

Make sure that the unit is off before proceeding with the step below.

4. While pressing and holding the reset button on the bottom of the unit using a small blunt object, push the on/off button. Release the on/off button as soon as the unit beeps once, but continue to hold the reset button as long as the unit's LED is lit or for about 10 seconds.

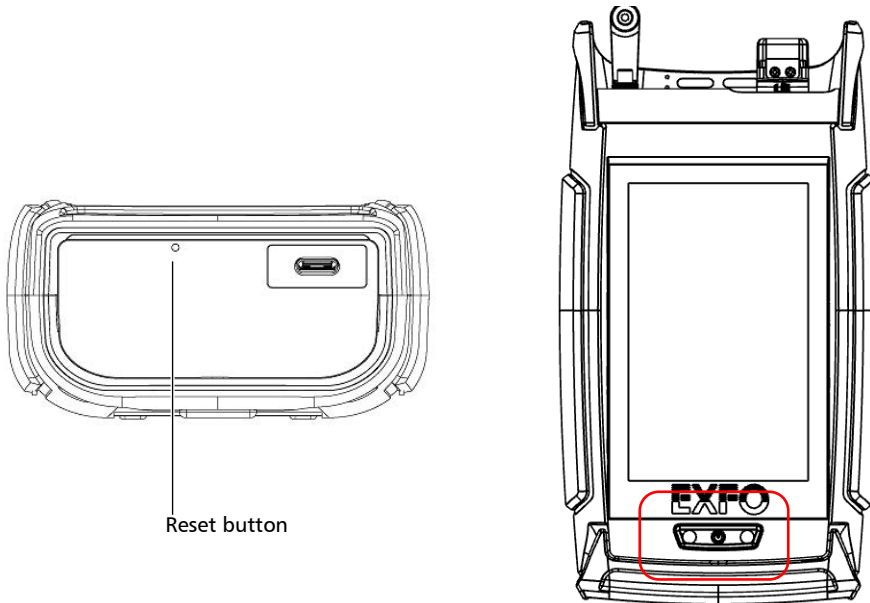



## CAUTION

**DO NOT TURN OFF** your unit while the recovery operation is underway. Doing so may damage your unit. Damaged units will need to be sent back to EXFO for repair.

5. In the recovery menu, select which task you want to do by tapping on the screen to go from one to the next until you highlight the desired one.

```

--- EXFO Recovery ---
Tap screen to cycle highlight
Press power button to confirm

reboot system now
USB update
wipe data/factory reset
    
```

6. Once your choice is highlighted, press the on/off button to start the task, then follow the on-screen instructions.
7. Once your unit has restarted, set the operation language, read and accept the EXFO license agreement, configure the date and time, and select the desired distance units as you did when you first received your unit.
8. Once your unit has restarted, configure the regional parameters, and reconnect your unit to your smart device as you did when you first received your unit (see *Configuring Your Unit at First Startup* on page 21).

## Accessing the Online Documentation From the AXS Handheld OTDR

You can access the user guide at all times from your smart device by scanning the QR code displayed on your unit.

**To access the user guide with the QR code:**

1. From the main menu, tap .
2. Scan the QR code with your smart device.

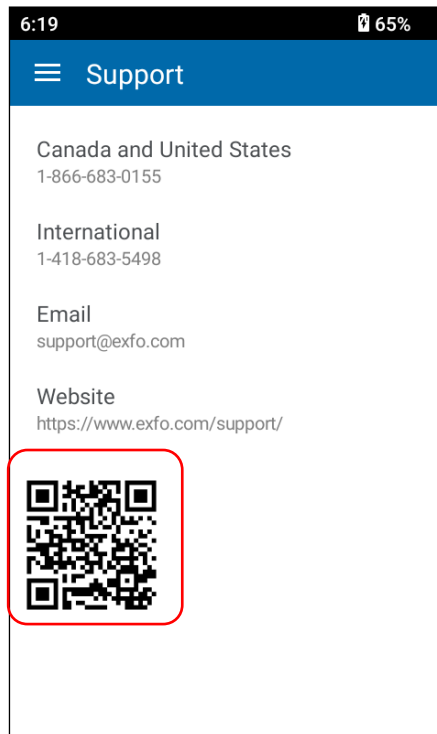

## **Contacting the Technical Support Group**

To obtain after-sales service or technical support for this product, contact EXFO at one of the following numbers. The Technical Support Group is available to take your calls from Monday to Friday, 8:00 a.m. to 7:00 p.m. (Eastern Time in North America).

### **Technical Support Group**

400 Godin Avenue  
Quebec (Quebec) G1M 2K2  
CANADA

1 866 683-0155 (USA and Canada)  
Tel.: 1 418 683-5498  
Fax: 1 418 683-9224  
support@exfo.com

For detailed information about technical support, and for a list of other worldwide locations, visit the EXFO Web site at [www.exfo.com](http://www.exfo.com).

If you have comments or suggestions about this user documentation, you can send them to [customer.feedback.manual@exfo.com](mailto:customer.feedback.manual@exfo.com).

To accelerate the process, please have information such as the name and the serial number (see the product identification label), as well as a description of your problem, close at hand.

## Viewing System Information

You can easily access important information such as the model of your unit, the serial number, the software and hardware versions, as well as the latest hardware calibration, directly from your unit. You can also find the contact information if you ever need to reach EXFO.

### *To view the system information:*

1. From the main menu, tap .
2. Under **Unit settings**, tap **About**.

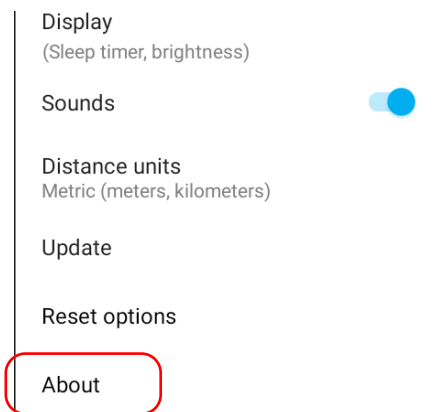

**To retrieve the contact information:**

1. From the main menu, tap .
2. The information you want to view is displayed on screen.

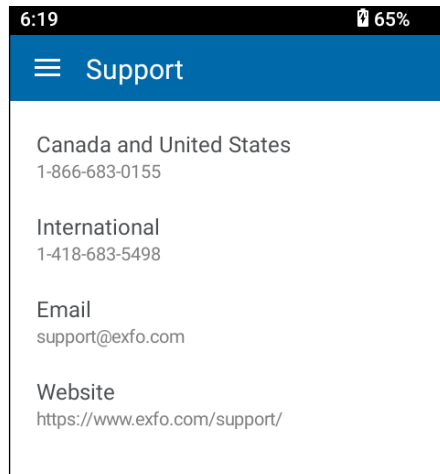

## Transportation

Maintain a temperature range within specifications when transporting the unit. Transportation damage can occur from improper handling. The following steps are recommended to minimize the possibility of damage:

- Pack the unit in its original packing material when shipping.
- Avoid high humidity or large temperature fluctuations.
- Keep the unit out of direct sunlight.
- Avoid unnecessary shocks and vibrations.

# 12 Warranty

## General Information

EXFO Inc. (EXFO) warrants this equipment against defects in material and workmanship for a period of one year from the date of original shipment. EXFO also warrants that this equipment will meet applicable specifications under normal use.

During the warranty period, EXFO will, at its discretion, repair, replace, or issue credit for any defective product, as well as verify and adjust the product free of charge should the equipment need to be repaired or if the original calibration is erroneous. If the equipment is sent back for verification of calibration during the warranty period and found to meet all published specifications, EXFO will charge standard calibration fees.



### IMPORTANT

The warranty can become null and void if:

- unit has been tampered with, repaired, or worked upon by unauthorized individuals or non-EXFO personnel.
- warranty sticker has been removed.
- case screws, other than those specified in this guide, have been removed.
- case has been opened, other than as explained in this guide.
- unit serial number has been altered, erased, or removed.
- unit has been misused, neglected, or damaged by accident.

THIS WARRANTY IS IN LIEU OF ALL OTHER WARRANTIES EXPRESSED, IMPLIED, OR STATUTORY, INCLUDING, BUT NOT LIMITED TO, THE IMPLIED WARRANTIES OF MERCHANTABILITY AND FITNESS FOR A PARTICULAR PURPOSE. IN NO EVENT SHALL EXFO BE LIABLE FOR SPECIAL, INCIDENTAL, OR CONSEQUENTIAL DAMAGES.

## **Gray Market and Gray Market Products**

Gray market is a market where products are traded through distribution channels that are legal but remain unofficial, unauthorized, or unintended by the original manufacturer. Intermediaries using such channels to distribute products are considered to be part of the gray market (hereafter unauthorized intermediary).

EXFO considers that a product originates from the gray market (hereafter gray market product) in the following situations:

- A product is sold by an unauthorized intermediary.
- A product is designed and destined for a particular market and sold on a second market.
- A product is resold, despite being reported lost or stolen.

When products are purchased on the gray market, rather than through an authorized EXFO distribution channel, EXFO is unable to guarantee the source and quality of those products nor the local safety regulations and certifications (CE, UL, etc.).

EXFO will not honor warranty, install, maintain, repair, calibrate, provide technical support nor make any support contracts available for gray market products.

For complete information, refer to EXFO's policy regarding gray market products at

[www.exfo.com/en/how-to-buy/sales-terms-conditions/gray-market/](http://www.exfo.com/en/how-to-buy/sales-terms-conditions/gray-market/)

## Liability

EXFO shall not be liable for damages resulting from the use of the product, nor shall be responsible for any failure in the performance of other items to which the product is connected or the operation of any system of which the product may be a part.

EXFO shall not be liable for damages resulting from improper usage or unauthorized modification of the product, its accompanying accessories and software.

## Exclusions

EXFO reserves the right to make changes in the design or construction of any of its products at any time without incurring obligation to make any changes whatsoever on units purchased. Accessories, including but not limited to fuses, pilot lamps, batteries and universal interfaces (EUI) used with EXFO products are not covered by this warranty.

This warranty excludes failure resulting from: improper use or installation, normal wear and tear, accident, abuse, neglect, fire, water, lightning or other acts of nature, causes external to the product or other factors beyond the control of EXFO.



### **IMPORTANT**

In the case of products equipped with optical connectors, EXFO will charge a fee for replacing connectors that were damaged due to misuse or bad cleaning.

## Certification

EXFO certifies that this equipment met its published specifications at the time of shipment from the factory.

## Service and Repairs

EXFO commits to providing product service and repair for five years following the date of purchase.

**To send any equipment for service or repair:**

- 1.** Call one of EXFO's authorized service centers (see *EXFO Service Centers Worldwide* on page 206). Support personnel will determine if the equipment requires service, repair, or calibration.
- 2.** If equipment must be returned to EXFO or an authorized service center, support personnel will issue a Return Merchandise Authorization (RMA) number and provide an address for return.
- 3.** If possible, back up your data before sending the unit for repair.
- 4.** Pack the equipment in its original shipping material. Be sure to include a statement or report fully detailing the defect and the conditions under which it was observed.
- 5.** Return the equipment, prepaid, to the address given to you by support personnel. Be sure to write the RMA number on the shipping slip. *EXFO will refuse and return any package that does not bear an RMA number.*

**Note:** *A test setup fee will apply to any returned unit that, after test, is found to meet the applicable specifications.*

After repair, the equipment will be returned with a repair report. If the equipment is not under warranty, you will be invoiced for the cost appearing on this report. EXFO will pay return-to-customer shipping costs for equipment under warranty. Shipping insurance is at your expense.

Routine recalibration is not included in any of the warranty plans. Since calibrations/verifications are not covered by the basic or extended warranties, you may elect to purchase FlexCare Calibration/Verification Packages for a definite period of time. Contact an authorized service center (see *EXFO Service Centers Worldwide* on page 206).

## **EXFO Service Centers Worldwide**

If your product requires servicing, contact your nearest authorized service center.

### **EXFO Headquarters Service Center**

400 Godin Avenue  
Quebec (Quebec) G1M 2K2  
CANADA

1 866 683-0155 (USA and Canada)  
Tel.: 1 418 683-5498  
Fax: 1 418 683-9224  
support@exfo.com

### **EXFO Europe Service Center**

Winchester House, School Lane  
Chandlers Ford, Hampshire S053 4DG  
ENGLAND

Tel.: +44 2380 246800  
Fax: +44 2380 246801  
support.europe@exfo.com

### **EXFO Telecom Equipment (Shenzhen) Ltd.**

3rd Floor, Building C,  
FuNing Hi-Tech Industrial Park, No. 71-3,  
Xintian Avenue,  
Fuhai, Bao'An District,  
Shenzhen, China, 518103

Tel: +86 (755) 2955 3100  
Fax: +86 (755) 2955 3101  
support.asia@exfo.com

To view EXFO's network of partner-operated Certified Service Centers nearest you, please consult EXFO's corporate website for the complete list of service partners:

<https://www.exfo.com/en/services/field-network-testing/exfo-service-centers>.

## Index

* .....	136
< .....	130
> .....	130

### A

AC requirements .....	16, 18
accessing online help .....	198
acquisition	
changing resolution .....	75
duration .....	30
time selection .....	75
acquisition modes .....	58
adapter .....	16
adding language .....	37
additional verifications on connectors.....	188
adjusting	
brightness.....	33
date, time and time zone .....	45
after-sales service .....	199
APC-type connector.....	87, 90
applications, installing .....	178
arrows, navigation .....	127, 131
auto navigation	
disabling.....	57
enabling .....	57
auto save	
disabling.....	56
enabling .....	56
auto test mode.....	30
automated OPM measurement .....	94
automatically saving measurements.....	140
available models.....	4

### B

backlight, setting.....	33
battery	
clock .....	165
level .....	160, 185
maintenance recommendations... ..	160, 163
purchasing new .....	164
recharging .....	3, 7, 160, 162
replacing or removing.....	165, 166
resetting information.....	81
status icons.....	6, 160, 185
status LED .....	2, 5, 160, 185
beep, enabling or disabling .....	36
beginning of the link .....	136
blinking	
LED .....	5
VFL signal.....	83
Bluetooth	
closing connection .....	146
data transfer .....	146
establishing connection .....	146, 147
frequency band data.....	xii
status .....	146, 147
upgrading software .....	178
boot, first .....	21
brightness	
adjusting.....	33
icon.....	34
button, on/off.....	2, 5, 162, 166, 189

### C

caution	
of personal hazard .....	10
of product hazard .....	10
changing	
battery .....	165, 166
connector.....	175
date and time .....	45



duration of acquisition ..... 30  
dynamic range, insufficient ..... 131

**E**

editing IOR value ..... 68  
element  
  connector ..... 131, 136  
  diagnosis ..... 137  
  group ..... 131  
  macrobend ..... 131  
  out of range ..... 131  
  splice ..... 131, 136  
  table ..... 134  
  types, changed ..... 136  
enabling  
  auto navigation ..... 57  
  auto save ..... 56  
  power measurements ..... 54  
  sounds ..... 36  
  Wi-Fi ..... 149

end

  of acquisition, audible signal ..... 36  
  of fiber detection thresholds ..... 72  
  of the link ..... 136  
equipment returns ..... 205  
establishing a connection  
  via Bluetooth ..... 146, 147  
  via Wi-Fi ..... 149  
Exchange mobile application, installing .... 145  
EXFO Exchange mobile application ..... 144  
existing measurement ..... 89  
exporting measurements ..... 141  
external power supply ..... 16

**F**

factory settings ..... 81, 194  
fail status ..... 63, 130  
feet, distance units ..... 47  
fiber ends, cleaning ..... 31

fibers

  launch and receive ..... 60  
  testing ..... 86, 89  
first  
  element on link ..... 136  
  startup ..... 21  
forget networks ..... 155  
frequency, Bluetooth and Wi-Fi ..... xii  
front panel, cleaning ..... 158

**G**

group of elements ..... 131, 133

**H**

hard reboot ..... 194  
help, online ..... 198  
high temperature ..... 8  
hour, setting ..... 45

**I**

icon

  battery status ..... 6, 160, 185  
  Bluetooth status ..... 146, 147  
  brightness ..... 34  
  connectors ..... 131  
  group ..... 131  
  macrobend ..... 131  
  out of range ..... 131  
  quick save ..... 29  
  source, on ..... 84, 126  
  splice ..... 131  
  Wi-Fi status ..... 151

identification

  measurement ..... 29  
  number ..... 131  
identification label ..... 199  
identifiers for test points ..... 101  
imperial units ..... 47  
indoor use ..... 16  
input current ..... 18

inserting battery..... 165, 166  
installing  
    Exchange mobile application ..... 145  
    software ..... 178  
interface, changing language..... 37  
internal  
    connector ..... 171, 175, 188, 189  
    temperature..... 7, 8  
IOR value, setting ..... 68  
IPv4 wireless routers characteristics..... 150

**J**

jobs  
    adding test points ..... 113  
    creating ..... 106  
    deleting ..... 111  
    deleting points ..... 116  
    description..... 99  
    list..... 99  
    performing measurements again..... 89  
    understanding ..... 99  
junction between fiber sections ..... 131

**K**

keyboard layout ..... 43  
kilofeet, distance units ..... 47  
kilometer, distance units ..... 47

**L**

label, identification ..... 199  
language  
    removing from list..... 41  
    selecting ..... 37  
last element on link..... 136  
launch fibers ..... 60  
    length ..... 130  
    setting ..... 61  
    specifications..... 87, 90

LED  
    battery status..... 2, 160, 185  
    indicators ..... 5  
light emission ..... 120, 122, 126  
link  
    end, letter B ..... 136  
    length ..... 29  
    start, letter A..... 136  
    summary..... 130  
    worst loss and ORL values..... 130  
link results  
    area..... 29  
    pass/fail status ..... 130  
Li-Po battery ..... 7, 160  
list  
    of networks, removing item from ..... 155  
    of test points ..... 100  
loss value, by wavelength ..... 130

**M**

macroband ..... 72, 131  
main features ..... 1  
main window description ..... 28  
maintenance  
    battery ..... 160, 163  
    front panel ..... 158  
    general information ..... 158  
    screen ..... 160  
manual ..... 198  
manually saving measurements..... 140  
markers ..... 94  
markers on trace..... 138  
maximum input current..... 18  
measurements  
    distance units..... 47  
    exporting ..... 141  
    identification..... 29  
    loss ..... 29  
    ORL ..... 29  
    performing..... 86  
    range ..... 30

saving ..... 140  
 status..... 63, 130  
 stopped, source..... 120, 126  
 viewing..... 127  
 measuring  
   power automatically ..... 97  
   power manually ..... 94  
 mechanical connector cleaning ..... 159  
 meter, distance units ..... 47  
 metric units ..... 47  
 mobile application ..... 144  
 mode  
   auto test ..... 30  
   real-time ..... 30, 90  
 models  
   available ..... 4  
   with Click-Out connector ..... 171, 188, 189  
   without Click-Out connector..... 171, 189  
 modes for tests ..... 58  
 modifying  
   acquisition time ..... 75  
   distance range ..... 75  
   element type..... 136  
   pulse width..... 75  
 modulation, light source ..... 120, 122  
 monitoring fibers in real time..... 90  
 muting unit ..... 36  
 my jobs page..... 99

**N**

navigation arrows ..... 89, 127, 131  
 non-reflective events ..... 72

**O**

obtaining batteries ..... 164  
 off LED ..... 5  
 on/off button ..... 2, 5, 162, 166, 189  
 online help ..... 198  
 on-screen keyboard ..... 43  
 operation language..... 37  
 OPM measurement, saving..... 94

optical  
   Click-Out connector ..... 175, 188, 189  
   output diagnosis ..... 171  
   port..... 2, 3  
 optical link map  
   area..... 30, 131  
   connectors ..... 131  
   group of elements ..... 131, 133  
   macro bend ..... 131  
   out of range..... 131  
   splice..... 131  
 Optimodes..... 58  
 options, Bluetooth..... 146  
 ORL, value by wavelength..... 130  
 OTDR trace viewer ..... 138  
 out of range element..... 131

**P**

parameters  
   acquisition time ..... 75  
   distance range ..... 75  
   pulse width ..... 75  
 pass status..... 63, 130  
 pass/fail  
   audible signal..... 36  
   status displayed ..... 130  
   status for a group of elements..... 133  
   thresholds ..... 63, 130  
 PDF report ..... 141  
 performing  
   job measurements ..... 86  
   job measurements again ..... 89  
 Pinyin keyboard ..... 43  
 port  
   detector ..... 2, 3  
   USB ..... 3  
   VFL..... 2, 3  
 power  
   adapter ..... 7, 162  
   bank..... 7, 162  
   button ..... 2, 5, 162, 166, 189

management ..... 49  
 measurements, configuring settings..... 54  
*see also* battery  
*see also* USB power adapter  
 sources ..... 18  
 supply ..... 16  
 power checker  
   audible signal ..... 36  
   using ..... 94  
 preset acquisition modes ..... 58  
 preventing automatic Wi-Fi connection..... 155  
 product  
   identification label ..... 199  
   specifications ..... 9  
 pulse width  
   selection ..... 75  
   selector ..... 30  
 purchasing new batteries ..... 164  
 putting internal connector back in place... 189

**Q**

quick save icon ..... 29

**R**

range ..... 30  
 ratio, splitter ..... 78  
 real-time mode ..... 30, 90  
 receive fibers ..... 60  
   length ..... 130  
   specifications ..... 87, 90  
 receiving data via Bluetooth ..... 146  
 recharging the battery ..... 7, 160, 162  
 reconnecting internal connector ..... 189  
 recovery mode ..... 194  
 red LED ..... 185  
 regional and language settings ..... 21  
 regulatory information ..... vii, viii, xi  
 removing  
   battery ..... 165, 166  
   configured networks ..... 155  
   languages ..... 41

replaceable Click-Out connector 171, 188, 189  
 replacement batteries ..... 164  
 replacing  
   battery ..... 81, 165, 166  
   connector ..... 175  
 results  
   table format ..... 134  
   trace ..... 138  
 return merchandise authorization (RMA) .. 205  
 reverting unit to initial state ..... 194

**S**

safety  
   caution ..... 10  
   conventions ..... 10  
   warning ..... 10  
 saturation level, detector ..... 130  
 saving  
   OPM measurement automatically  
     with OTDR measurement ..... 97  
 saving measurements  
   manually or automatically ..... 140  
   OPM ..... 94  
   other formats ..... 141  
 selecting  
   distance units ..... 47  
   language ..... 37  
   modulation ..... 120, 122  
   test configuration ..... 118  
   time zone ..... 45  
   wavelengths ..... 52  
 sending data via Bluetooth ..... 146  
 sequential number ..... 131  
 service and repairs ..... 205  
 service centers ..... 206  
 setting  
   acquisition time ..... 75  
   brightness ..... 33  
   date and time ..... 45  
   distance range ..... 75  
   IOR value ..... 68

launch fiber length .....	61	summary results .....	130
pass/fail thresholds .....	63	symbols, safety .....	10
power measurements .....	54	synchronizing job results .....	156
pulse width .....	75		
reset .....	81, 194	<b>T</b>	
sleep mode .....	49	table, elements .....	134
software update .....	178	technical specifications .....	9
sound notifications .....	36	technical support .....	199
timer, source .....	120, 122, 126	temperature for storage .....	158
Wi-Fi communication .....	149	temperature management .....	8
shipping to EXFO .....	205	test configurations .....	118
shortcut menu .....	30	test fibers	
shutting down .....	20	launch and receive .....	60
signal		specifications .....	87, 90
strength, Wi-Fi .....	151	test modes .....	58
to-noise ratio .....	75	test points	
sleep mode .....	20, 49	adding .....	113
software, installing and upgrading .....	178	deleting .....	116
sor format traces .....	141	description .....	100
sound notifications .....	36	generating identifiers .....	101
source		page .....	100
measurement stopped .....	120, 126	understanding .....	100
modulation .....	120, 122	testing fibers .....	86, 89
on, icon .....	84, 126	three-line menu .....	29
performing measurements .....	120, 121	thresholds	
specifications, product .....	9	end-of-fiber detection .....	72
splice .....	131, 136	splice loss .....	72
splice loss, detection thresholds .....	72	time zone, selecting .....	45
splitter ratio .....	78	timer, light emission .....	120, 122
status		title bar .....	29, 151
Bluetooth .....	146, 147	tone detector .....	94
fail .....	130	touchscreen	
pass .....	130	cleaning .....	160
star rating .....	63	location .....	2
unknown .....	130	trace viewer .....	94, 138
Wi-Fi .....	151	transferring	
stopping		data via Bluetooth .....	146
measurement, source .....	120, 126	data with Wi-Fi .....	149
Wi-Fi communication .....	149	transportation requirements .....	158, 201
storage requirements .....	158	trc format traces .....	141
strength of the signal .....	151		
sub-element in grouped elements .....	133		

turning on/off	
sounds .....	36
source .....	121
unit .....	19, 20
VFL .....	83
Wi-Fi .....	149
types of connectors .....	87, 90

## U

unit	
damaged connector .....	175
first configuration .....	21
restoring .....	194
unexpected shutdown .....	8
ventilation .....	16
unknown status .....	63, 130
UPC-type connector .....	87, 90
updating applications .....	178
USB	
port .....	3
power adapter .....	7, 162
power bank .....	7, 162
upgrading application .....	180
user guide .....	198
using	
launch fibers .....	61
light source .....	120, 121
markers .....	138
test fibers .....	87, 90

## V

value	
loss and ORL, by wavelength .....	130
worst link loss and ORL .....	130
ventilation .....	16
verifications before repairs .....	188
verifying optical output .....	171
VFL	
port location .....	2, 3
using .....	83
viewing	

link results .....	130
measurements .....	127
results in optical link map .....	131
results in table .....	134

## W

warranty	
certification .....	204
exclusions .....	204
general .....	202
liability .....	204
null and void .....	202
wavelengths	
setting .....	52
viewing values .....	130
Wi-Fi	
frequency band data .....	xii
status .....	151
wireless	
IPv4 routers characteristics .....	150
networks removed from list .....	155
wizard, configuration .....	21
working with	
launch fibers .....	61
link results .....	130
optical link map .....	131
pass/fail thresholds .....	63
worst link loss and ORL values .....	130

## Z

zoom .....	94
------------	----

CHINESE REGULATION ON RESTRICTION OF HAZARDOUS SUBSTANCES (RoHS)  
中国关于有害物质限制的规定

NAMES AND CONTENTS OF THE TOXIC OR HAZARDOUS SUBSTANCES OR ELEMENTS  
CONTAINED IN THIS EXFO PRODUCT  
包含在本 EXFO 产品中的有毒有害物质或元素的名称及含量

Part Name 部件名称	Lead 铅 (Pb)	Mercury 汞 (Hg)	Cadmium 镉 (Cd)	Hexavalent Chromium 六价铬 (Cr(VI))	Polybrominated biphenyls 多溴联苯 (PBB)	Polybrominated diphenyl ethers 多溴二苯醚 (PBDE)
Enclosure 外壳	O	O	O	O	O	O
Electronic and electrical sub-assembly 电子和电气组件	X	O	X	O	X	X
Optical sub-assembly <sup>a</sup> 光学组件 <sup>a</sup>	X	O	O	O	O	O
Mechanical sub-assembly <sup>a</sup> 机械组件 <sup>a</sup>	O	O	O	O	O	O

Note:

注:

This table is prepared in accordance with the provisions of SJ/T 11364.

本表依据 SJ/T 11364 的规定编制。

O: Indicates that said hazardous substance contained in all of the homogeneous materials for this part is below the limit requirement of GB/T 26572.

O: 表示该有害物质在该部件所有均质材料中的含量均在 GB/T 26572 标准规定的限量要求以下。

X: indicates that said hazardous substance contained in at least one of the homogeneous materials used for this part is above the limit requirement of GB/T 26572. Due to the limitations in current technologies, parts with the "X" mark cannot eliminate hazardous substances.

X: 表示该有害物质至少在该部件的某一均质材料中的含量超出 GB/T 26572 标准规定的限量要求。



标记 "X" 的部件, 皆因全球技术发展水平限制而无法实现有害物质的替代。

a. If applicable.

如果适用。

MARKING REQUIREMENTS

标注要求

Product 产品	Environmental protection use period (years) 环境保护使用期限 (年)	Logo 标志
This EXFO product 本 EXFO 产品	10	
Battery <sup>a</sup> 电池	5	

a. If applicable.  
如果适用。



[www.EXFO.com](http://www.EXFO.com) · [info@EXFO.com](mailto:info@EXFO.com)

---

**CORPORATE HEADQUARTERS** 400 Godin Avenue

Quebec (Quebec) G1M 2K2 CANADA  
Tel.: 1 418 683-0211 · Fax: 1 418 683-2170

---

**TOLL-FREE** (USA and Canada)

1 800 663-3936

© 2026 EXFO Inc. All rights reserved.

